

UNINTERRUPTIBLE POWER SUPPLY
FREQUENCY CONVERTER
80 to 100 kVA
480V 60Hz / 400-230V 50Hz three-Phase Output



USER MANUAL



RPS SpA
Viale Europa 7
37045 Legnago (VR) Italy
www.riello-ups.com



Thank you for choosing our product.

RPS S.p.A. is highly specialized in the development and production of Frequency Converters (FC). The FC's of this series are high quality products, carefully designed and manufactured to ensure optimum performance.

Applicability

This manual applies to the following models of Frequency Converters:

MHT FC 80 UL P

80 kVA / 72kW, 480 V, 60Hz input 3P 3W - 400-230 V, 50Hz output 3P 4W.

MHT FC 100 UL P

100 kVA / 90kW, 480 V, 60Hz input 3P 3W - 400-230 V, 50Hz output 3P 4W.

SAFETY WARNINGS



The wye output configuration that provides an output neutral connection is only permitted when an input neutral is provided; delta-wye configuration is prohibited. The source must have a grounded neutral, even if the neutral is not connected to the FC; a delta source may not be ungrounded or corner grounded.

IMPORTANT SAFETY INSTRUCTIONS SAVE THESE INSTRUCTIONS

This manual contains important instructions for Models 80, 100 kVA MHT FC UL P Frequency Converters (FC) that should be followed during installation and maintenance of the FC. Please read all instructions before operating the equipment and save this manual for future reference.

READ AND FOLLOW ALL SAFETY INSTRUCTIONS

- a. Do not use outdoors.**
- b. Do not route wiring across or near hot surfaces.**
- c. Do not install near gas or electric heaters.**
- d. Use caution when servicing batteries. Battery acid can cause burns to skin and eyes. If acid is spilled on skin or in eyes, flush acid with fresh water and contact a physician immediately.**
- e. Equipment should be installed where it will not readily be subjected to tampering by unauthorized personnel.**
- f. The use of accessory equipment not recommended by the manufacturer may cause an unsafe condition.**
- g. Do not use this equipment for other than intended use.**

DANGER



This FC contains LETHAL VOLTAGES. All repairs and service should be performed by AUTHORIZED SERVICE PERSONNEL ONLY. There are NO USER SERVICEABLE PARTS inside the FC.

WARNING



To reduce the risk of fire or electric shock, install this Frequency Converter in a temperature and humidity controlled, indoor environment, free of conductive contaminants. Do not operate near water or excessive humidity (95% maximum).

Input and output over-current protection and disconnect switches must be provided by others. High ground leakage current may be present. Do not operate the equipment without a proper protective ground.

WARNING



Batteries can present a risk of electrical shock or burn from high short circuit current. Observe proper precautions. Servicing should be performed by qualified service personnel knowledgeable of batteries and required precautions. Keep unauthorized personnel away from batteries.



There is a risk of explosion if batteries are replaced by an incorrect type. Replace with same type and rating only.

Proper disposal of batteries is required. Refer to your local codes for disposal requirements.

Never dispose of batteries in a fire

EMERGENCY INTERVENTIONS



The followings are general information.

First aid interventions

Company regulations and traditional procedures should be followed for any first aid intervention that may be required.

Firefighting measures



1. Do not use water to extinguish fire, but only fire extinguishers that are suitable for use with electrical and electronic equipment.
2. If exposed to heat or fire, some products may release toxic fumes into the atmosphere. Always use a respirator when extinguishing a fire.

DEFINITION OF “OPERATOR” AND “SPECIALIZED TECHNICIAN”



The professional figure responsible for accessing the equipment for ordinary maintenance purposes is defined with the term *operator*.

This definition covers personnel that know the operating and maintenance procedures for the equipment, and that have been:

1. Trained to operate in accordance with the safety standards relating to the dangers that may arise where electrical voltage is present.
2. Trained to use Personal Protective Equipment and to carry out basic first aid.







The professional figure responsible for the installation and start-up of the equipment, and for any extraordinary maintenance, is defined with the term *specialized technician*.

This definition covers personnel that, in addition to the requirements listed above for a general operator, must also:

1. Have been suitably trained by the manufacturers or their representative.
2. Be aware of installation, assembly, repair and service procedures, and have a specific technical qualification.
3. Must have a background of technical training, or specific training relating to the procedures for the safe use and maintenance of the equipment.

Symbols used in the manual

In this manual, some operations are shown by graphic symbols to alert the reader to the dangerous nature of the operations:

	Danger / Risk of Electric Shock <i>Possibility of serious injury or substantial damage to the device, unless adequate precautionary countermeasures are taken.</i>
	Caution <i>This symbol means that important information must be read with care.</i>
	Risk of Explosion
	Note
	Ground Connection
	Electrostatic Sensitive Device
	It is recommended to read the manual.







PERSONAL PROTECTIVE EQUIPMENT

No maintenance operations must be carried out on the device without wearing the Personal Protective Equipment (PPE) described below.

Personnel involved in the installation or maintenance of the equipment must not wear clothes with wide sleeves or laces, belts, bracelets or other items that may be dangerous, especially if they are metallic. Long hair must be tied in such a way as to ensure that it is not a hazard.

The following signs show the protective equipment that should be worn. The various items of PPE must be selected and sized according to the nature of the hazard (particularly electrical) posed by the equipment.

	Accident prevention footwear Use: always		Protective eyewear Use: always
	Protective clothing Use: always		Helmet Use: When there are suspended loads
	Work gloves Use: always		

GENERAL PRECAUTIONS



This manual contains detailed instructions for the use, installation and start-up of the FC. Read the manual carefully before installation. For information on using the FC, the manual should be kept close at hand and consulted before carrying out any operation on the device.

This equipment has been designed and manufactured in accordance with the standards for the product, for normal use and for all uses that may reasonably be expected. It may under no circumstances be used for any purposes other than those envisaged, or in any other ways than those described in this manual. Any interventions should be carried out in accordance with the criteria and the time-frames described in this manual.

No reproduction of any part of this manual, even partial, is permitted without the authorization of RPS S.p.A. The RPS S.p.A. reserves the right to modify the product described herein, to improve it, at any time and without notice.

CONTENTS

LAYOUT	9
PRELIMINARY OPERATIONS	10
<i>Removing the packaging and positioning the device</i>	10
<i>Storage</i>	10
<i>Handling</i>	10
INSTALLATION ENVIRONMENT	11
<i>Ambient conditions:</i>	11
<i>Dimensions of the premises</i>	11
<i>Cooling of the premises</i>	12
ELECTRICAL CONNECTIONS	13
<i>Accessing the FC terminals</i>	13
<i>FC -single module configuration</i>	14
1.1.1 <i>Cable Entry</i>	15
1.1.2 <i>Connection of Power Cables</i>	16
1.1.3 <i>Differential (GFI)</i>	17
1.1.4 <i>Emergency power off device (EPO)</i>	17
1.1.5 <i>Connection of signals and remote commands</i>	18
1.1.6 <i>Remote commands, alarms and EPO</i>	20
1.1.7 <i>RS232</i>	21
1.1.8 <i>SLOT 1 and SLOT 2</i>	22
<i>following cards may be inserted (optional):</i>	22
1.1.9 <i>Remote alarms (optional cards)</i>	23
1.1.10 <i>Modem (optional)</i>	23
1.1.11 <i>Multi I/O (optional)</i>	23
1.1.12 <i>Battery temperature sensor (optional)</i>	23
1.1.13 <i>Battery temperature alarm (optional)</i>	23
1.1.14 <i>Multi Panel</i>	23
1.1.15 <i>Start-up</i>	24
1.1.15.1 <i>Before starting up procedure</i>	24
1.1.16 <i>Start up procedure</i>	24
1.1.16.1 <i>Multiple battery disconnect</i>	24
1.1.17 <i>Single FC and load shutdown</i>	24
CONTROL PANEL AND DISPLAY	25
GRAPHIC DISPLAY	27
1.1.18 <i>Basic menu (text lines area)</i>	29
1.1.19 <i>The first line of the basic menu</i>	29
1.1.20 <i>The second line of the basic menu</i>	29
1.1.21 <i>Language setting menu (keys 1, 1)</i>	30
1.1.22 <i>Measurements menus (key 2)</i>	31
1.1.23 <i>Full page Measurements and output waveforms (key 2,7)</i>	32
1.1.24 <i>Controls Menu (key 3)</i> ,.....	33
1.1.24.1 <i>Keys menu 3, 2: battery test</i>	33
1.1.24.2 <i>Customizing</i>	34
1.1.24.3 <i>Entering customized codes</i>	35
1.1.24.4 <i>Rated output voltage.</i>	35
1.1.24.5 <i>Battery</i>	36
1.1.24.6 <i>Cyclic battery recharging</i>	36
1.1.24.7 <i>Two- level recharging</i>	37
1.1.24.8 <i>PRE-ALARM</i>	37
1.1.24.9 <i>AUTO-OFF Timer</i>	39
1.1.24.10 <i>Modem set-up</i>	39

1.1.24.11	"dial /send " modem.....	40
1.1.24.12	RS232.....	40
1.1.24.13	Echo	41
1.1.24.14	Ident	41
1.1.24.15	Total block	41
1.1.25	"Recorder": recorder events (key 4).....	41
1.1.25.1	Recorded voltages measurements	42
1.1.25.2	Recorded codes	42
1.1.25.3	Recorded value on full page.....	42
1.1.26	Disabling the audible alarm (key 5).....	44
1.1.27	"Clock": date/time (key 6).....	44
1.1.28	"Arrow down": Internal Codes, firmware ver.(key 7).....	44
MAINTENANCE		45
1.1.29	Maintenance inside the FC (trained personnel only).....	45
1.1.30	Planned maintenance for batteries (trained personnel only).....	45
GENERAL CHARACTERISTICS.....		46
RATED CURRENTS.....		48
APPENDIX A ALARM MESSAGES		49
APPENDIX B - OPTIONAL REMOTE COMMANDS		51

Layout

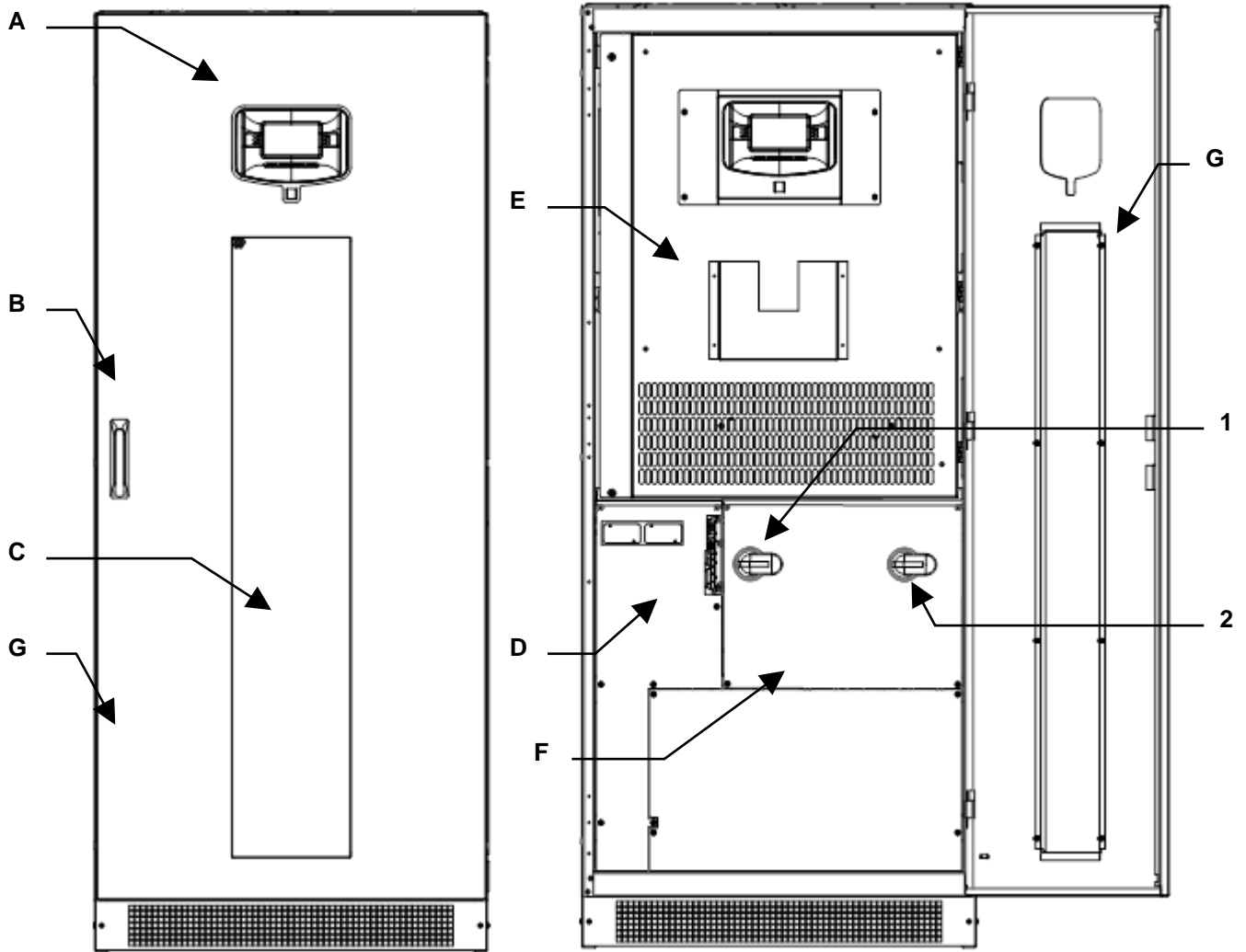

Figure 1- Cabinet front view

- A Control panel with graphic display
- B Door handle
- C Ventilation grilles
- D Communication area
- E Front Cover panel with ventilation grilles
- F Switch cover panel
- G Door

- 1 SWIN: Input power switch
- 2 SWOUT: Static switch output

Preliminary operations

Removing the packaging and positioning the device

On delivery, the packaging must be inspected to ensure that it is whole and that it has not been crushed or dented. Check in particular that neither of the two impact resistant devices on the packaging is red; if one of them is red; follow the instructions on the packaging.

The essential details of the device are provided on the shipping document. The marking, weight and dimensions of the various items making up the packing list are shown.

Check the state of the device by means of a visual inspection of both the inside and the outside. Any dents seen mean that it has suffered shocks during shipping, which could compromise the normal operation of the device.

During inspection, you may notice that a flat cable is left unconnected from one of the Circuit Cards on the back of the inner front door. The reason for this is as follows: The FC is supplied with the paralleling controls as standard, but the FC is shipped with this feature disabled. **DO NOT** connect this cable for standalone (non-parallel) operation.

Storage

Place the device in covered premises that are protected from direct contact with atmospheric agents and dust. The following environmental values are those allowed in the storage area:

Temperature:	-13°F to +167°F (-25 to + 75 °C)
Relative humidity:	30-95 % max.



For the installation of a battery cabinet, if provided with the FC, follow the instructions given in the specific manual.

The list of material provided may vary depending on the order specifications. As a general rule, the packaging should include the following: this manual, the installation drawing, the warranty and eventual accessories.

Handling

The equipment must only be handled by adequately trained personnel. It can be unloaded from the vehicle and put into place by lifting the box or the wooden deck to which the equipment is secured with a fork-lift truck. A fork-lift truck should be used for the permanent positioning of the equipment, in accordance with the instructions provided below.

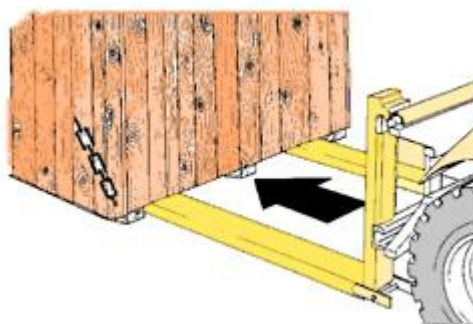

- 1 Insert the forks of the fork-lift truck in the lower part of the device, from the front or back, and ensure that they stick out about 12 inches on the other side.
- 2 Secure the device to the fork-lift before moving it.

Risk of overturning



To avoid the risk of the equipment overturning, ensure that it is firmly secured to the fork-lift truck by means of appropriate ropes before moving it.

When being moved the cabinet should be handled with care; shocks or drops can damage it. Once in position, remove the packaging carefully in order not to scratch the device.

The packaging should be removed as follows:

1. Cut the bands
2. Slide away the carton from above.
3. Remove the screws securing the cabinet to the wooden base.

Installation environment

The FC have been designed for indoor installation. The choice of premises for installation should comply with the points set out below.

Ambient conditions:

- Ensure that the floor can support the weight of the FC
- Ensure that the ambient temperature conforms to the following:
 - *minimum operating temperature:* +32°F (0 °C)
 - *maximum temperature for 8 hours a day:* +104°F (+ 40°C)
 - *average temperature for 24 hours:* +95°F (+ 35°C)

Dimensions of the premises

For the mechanical dimensions of the cabinets, refer to the “**INSTALLATION DRAWINGS**” supplied with the FC. These drawings provide the following data:

- the position of the holes in the base to secure the device to the floor, if applicable;
- a view of the floor support for the sizing of a structure to raise the cabinet, if applicable;
- the position of cable entry;
- the position of the fans on the top of the FC, for the positioning of a structure to convey the warm air discharged by the equipment outside the premises, if applicable;
- the input, output and battery cables section;
- the power dissipated by the equipment (kW).

Cooling of the premises

The recommended operating temperature for the lifetime of the Frequency Converter (FC) and of the batteries is between 20 and 25°C. The lifespan of the battery depends on the operating temperature; with an operating temperature increase from 20°C to 30°C, the lifespan of the batteries is halved.

The correct airflow is by fans located inside the FC (forced convection) and by the air around the side panels (natural convection).

To ensure proper air circulation measures must be taken during installation to avoid any obstructions to the free circulation of air. These include the following:

- Ensure a distance of at least 24 inches from the ceiling, so as not to hinder airflow ,
- Leave a free space of at least 36 inches at the front of the equipment to ensure both the circulation of the air and installation and maintenance operations;
- With natural convection the thermal load is dissipated to the outside through the walls; Thus a cabinet placed against a wall or in a hollow dissipates less heat than one located in a free environment.

Follows this rule of thumb:

Leave at least one of the three side walls free: right, left or back.

- The bottom side kick panels must not be mounted for installations where cabinets are lined-up (placed side by side).

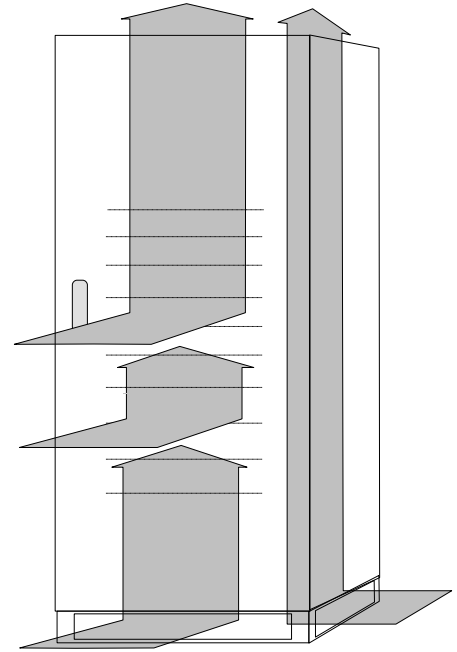

Electrical Connections

Accessing the FC terminals

Danger



The following operations must be performed while the FC is disconnected from the utility mains power, switched off and all the input and output power switches on the equipment are open. Before performing connection, open all the input and output power switches and check that the FC is completely isolated from all power sources: battery and AC power line. In particular, check that:

- FC input line is completely isolated;
- Battery circuit breaker/disconnect is open;
- all FC power and load connection switches (SWIN, and SWOUT) are in the open position;
- no dangerous voltages are present (use a DMM).

The first connection to be performed is the protective wire (earth ground cable) which must be inserted into the terminal labelled PE. The FC must operate with the grounding system connected.

Warning



Do not connect the output neutral to the input neutral.
If the input connection is Delta the FC can supply only Delta load.
The output neutral must not be connected unless the FC is the Wye version supplied with an input neutral TRANSFORMER BOXES (optional) are available for converting the distribution systems from 3 to 4 wires. If a three-phase non-linear load is connected to the output, the current on the neutral conductor can reach a value of 1.5 times the value of the phase current, dimension the input/output neutral cable appropriately. The FC cannot feed from a corner ground or mid-point grounded delta supply source.
Use only lugs or cables with tin-plated eyes for the connections.
Ensure correct phase sequence at the input and output terminals
Ensure correct polarity battery connections



Each model can be configured for a delta input source with a delta connected load or for a wye input with a wye connected load. If the load requires a neutral connection (i.e. wye), then an input neutral must be provided. Refer to the Power Connection terminals diagrams later in this section for details concerning configuration of the neutral to ground bond.

FC -single module configuration

The FC is designed to work as Single input Unit.

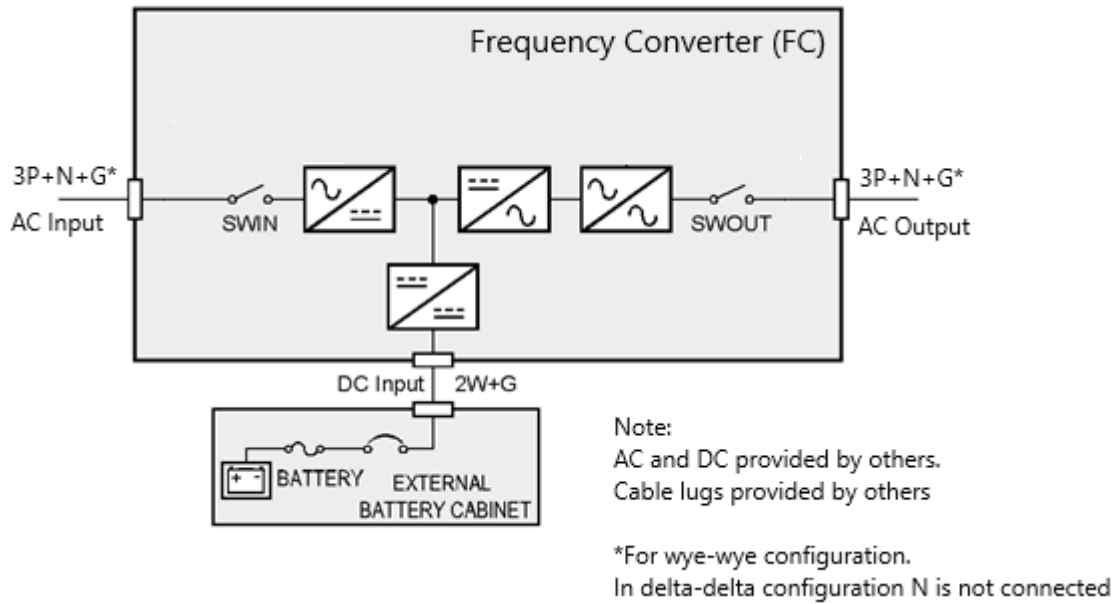

Figure 2- Block schematic of Frequency Converter

1.1.1 Cable Entry

The cables can enter in the FC from the bottom or from the top with the optional Top Cable Entry cabinet

Proceed as follows to open the FC

- Open the door
- Remove the switch cover panel
- Remove the bottom cable entry cover plates
- Drill or punch conduit holes in the cover plates
- Route the power cable through the bottom to the FC terminals in base to your configuration (see the next paragraphs)

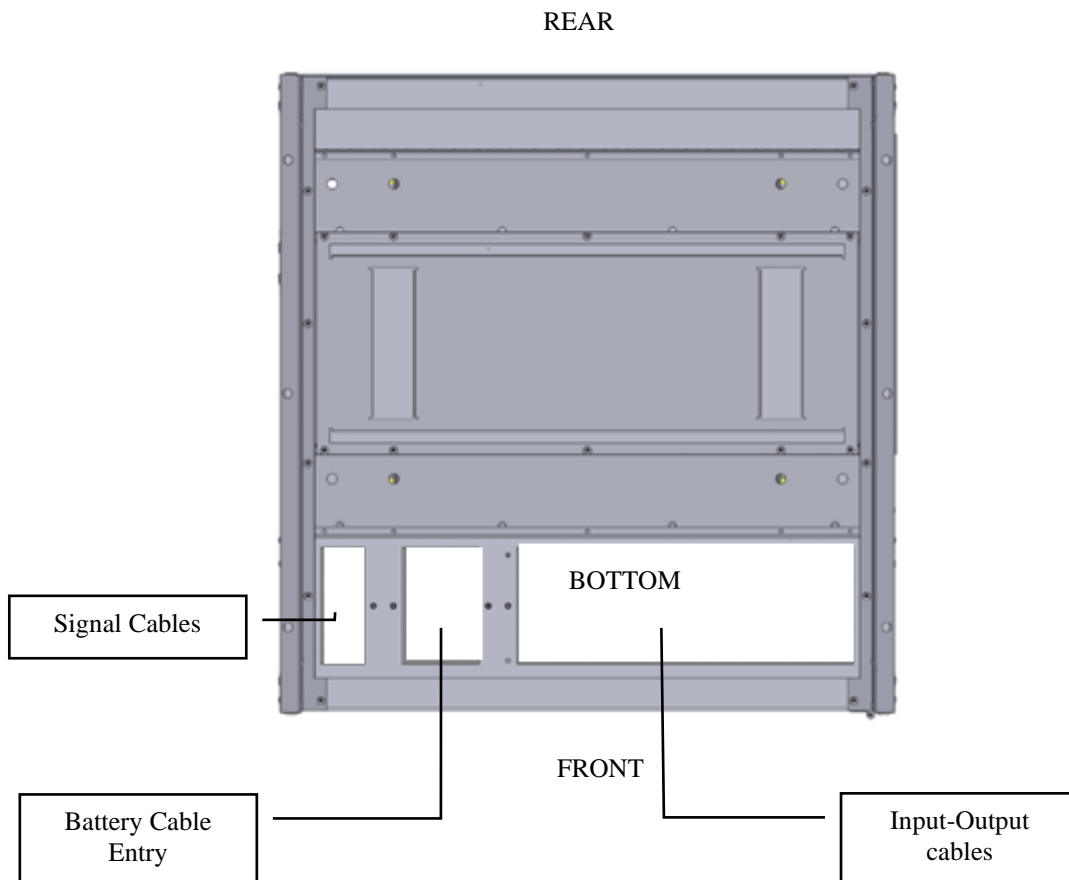

Figure 3- Bottom cable entry footprint

1.1.2 Connection of Power Cables

Connect the input, output and battery cables to the terminals as shown in the figure below:

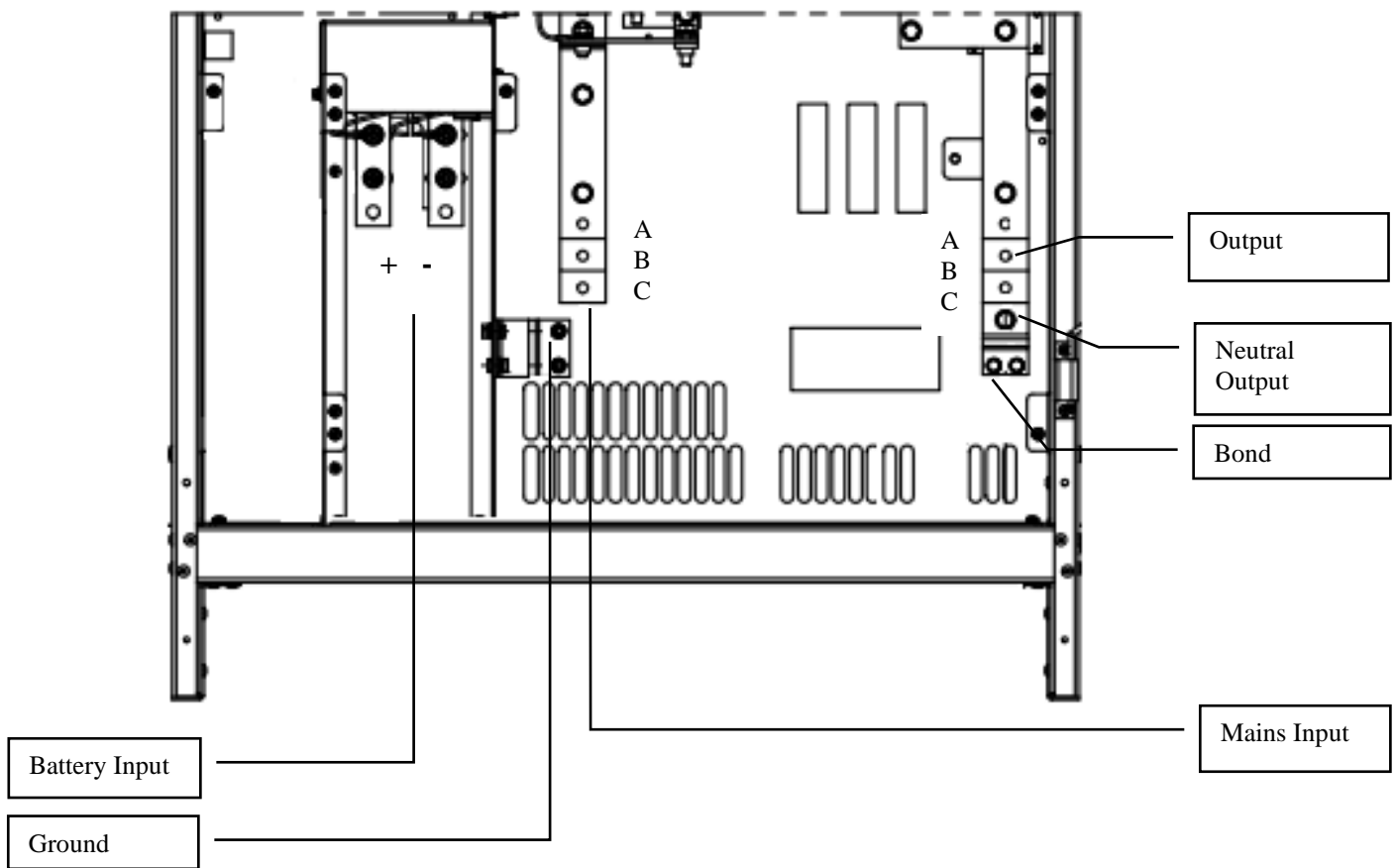

Figure 4- MHT FC UL 80-100 Power connection to field terminals



Note: For the Input, Output and Battery connections, respect the order from the top to bottom, or right to left, as described. The label marked “N” present on the terminal identifies the neutral terminal.



The FC is provided with a separate bus bar (bond) that connects the Neutral Output to the frame Ground for delta input connection. This is required to meet NEC grounding code for separately derived neutrals. When a Neutral is provided in a Wye configured input connection the bond must be removed.

Once installation has been completed inside the equipment, put the switch cover panel back and close the door.

1.1.3 Differential (GFI)

If the FC protection against electric shock uses a differential current device (Ground Fault Interrupter), it must have the following characteristics:

- Operating threshold 300mA
- Class A or B (DC and rectified AC)
- Insensitive to transient current pulses
- Delay ≥ 0.1 s.

neutral

 In the standard version, the neutral from the mains power supply is connected to the output neutral of the FC. ***THE ELECTRICAL SYSTEMS UPSTREAM AND DOWNSTREAM OF THE FC MUST BE EXACTLY THE SAME (DELTA-DELTA or WYE-WYE)***

When operating in the presence of mains supply, a differential breaker (GFCI) installed on the input will trip as the output circuit is not isolated from the input circuit.

When operating without mains supply (from battery) the input differential breaker will trip only if it is able to switch as a result of leakage current without any voltage at its poles (for example a differential breaker with an auxiliary relay is not suitable). However, it is possible to install additional differential breakers on the output of the FC, possibly coordinated with those on the input.

1.1.4 Emergency power off device (EPO)

The FC has an EPO (Emergency Power Off) function.

In the event of an emergency using this function the FC shuts down the rectifier and inverter and completely disconnects the power to the load

The Output circuit of the FC should not be considered safe, unless the FC is off and the input power source to the FC has been removed by opening the input disconnect devices which are external to the FC, including the battery.

This function can be activated from the button (under a hinged clear plastic cover) on the control panel or by a remote contact. This button must be depressed and held down until the FC shuts down.

On the FC, the jumper on the EPO terminal (a) must be removed, and the wires from the auxiliary contact of the button (b) must be connected in place of the jumper.

The contact must be closed with the button in the rest position and must open when the button is pressed.

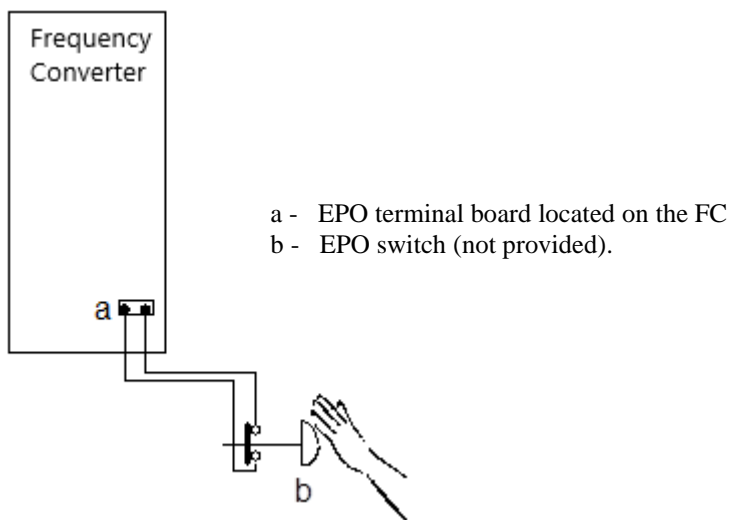

Figure 5 - Emergency Power Off (EPO)

1.1.5 Connection of signals and remote commands

To access the interface cards, open the door and remove the protection panel secured with screws (K) as shown in the drawing:

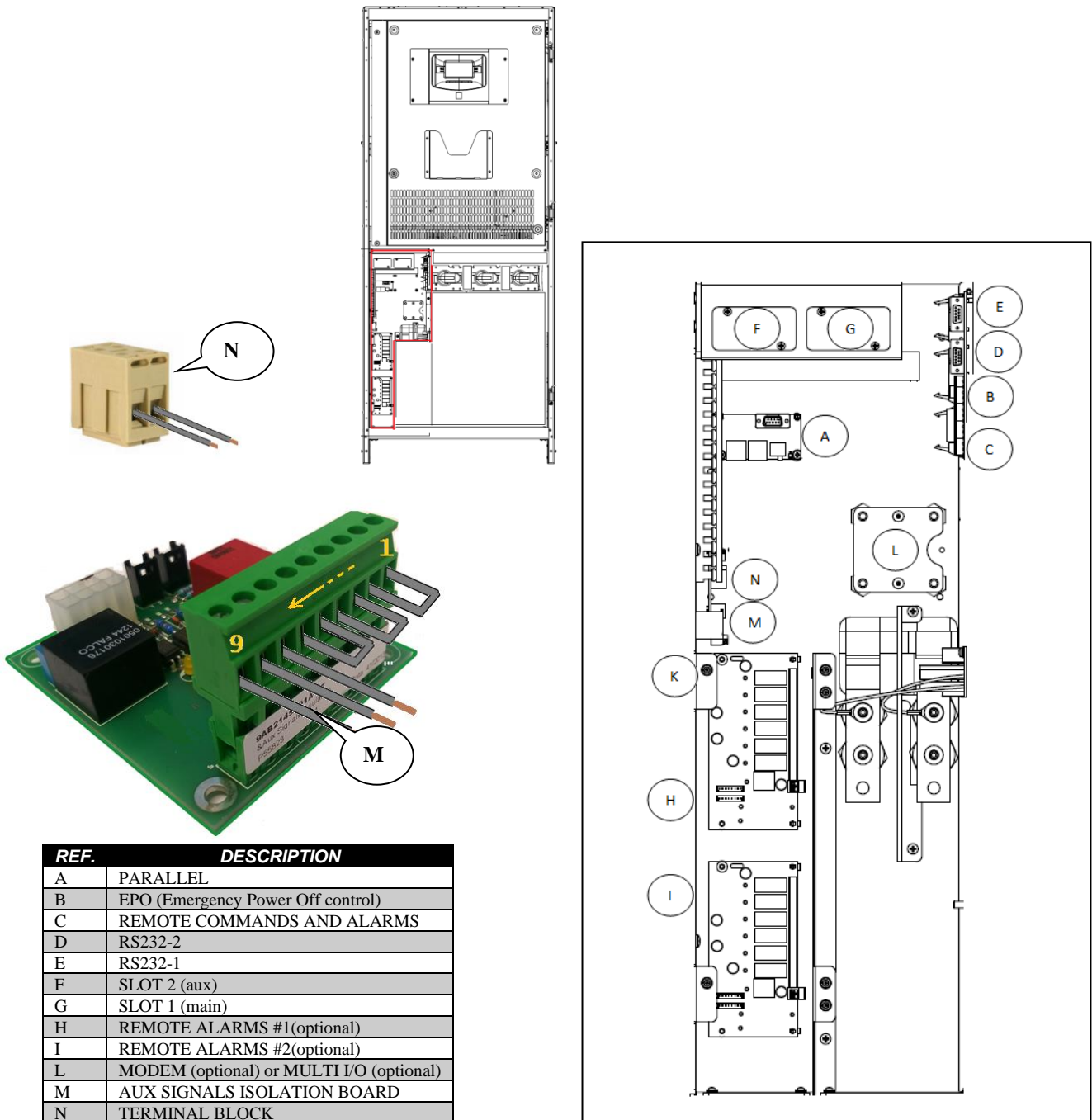

Figure 6- Signals and remote command connections



AUX SIGNALS ISOLATION BOARD allows receiving external auxiliary contacts and keeping them isolated from the FC internal circuits making easy connections in case of paralleling of the units. Jumpers AUX (SWBATT, SWMB, SWOUT) must be connected to the terminal of the board if no external auxiliary contacts are presents.

Table 1- Aux signals isolation boards

Connector J1 of Aux signals isolation board			
PIN	NAME	TYPE	FUNCTION
1	AUX SWBATT	INPUT	Dry contact (NO) used to indicate when SWBATT is closed
2	AUX SWBATT RETURN	INPUT	
3	AUX SWMB	INPUT	Dry contact (NC) used to indicate when the SWMB EXT is closed
4	AUX SWMB RETURN	INPUT	
5	AUX SWOUT	INPUT	Dry contact (NO) used to indicate when the SWOUT EXT is closed
6	AUX SWOUT RETURN	INPUT	
7	BAT. TEMP. SENSOR	INPUT	Ambient temperature from battery cabinet
8	BAT. TEMP. SENSOR	INPUT	
9	GROUND	INPUT	Shield cable to ground from temperature sensor

Terminal block			
PIN	NAME	TYPE	FUNCTION
1	SWBATT coil	OUTPUT	Dry contact (NO) used to supply SWBATT coil, in a circuit at 24Vdc.
2	SWBATT coil	OUTPUT	

Table 2- Torque specifications for board

Torque specifications for connector J1 on aux signals isolation board		
Wire size range	Torque Load	
#30 -12 AWG	0.37 – 0.44 lbf-ft	0.5 – 0.6 Nm
Torque specifications for terminal blocks on customer interface board		
Wire size range	Torque Load	
#22 -12 AWG	4.4 lbf-ft	6 Nm

1.1.6 Remote commands, alarms and EPO

The card is equipped with a 14 positions terminal board.



CIRCUIT PROVIDED. CONNECT TO SELV CIRCUIT ONLY.

POWER SUPPLY	1 power supply 12Vdc 80mA (max.) [pins 10 and 11];
ALARMS	3 FORM C dry contacts for alarms (rating 30 V AC / DC, 1 A);
COMMAND	1 command programmable by panel [pins 11 and 12];

Table 3- Remote commands alarms

<i>Interface REMOTE COMMAND ALARMS AND EPO</i>			
<i>PIN</i>	<i>NAME</i>	<i>TYPE</i>	<i>FUNCTION</i>
1,2,3	RL 1	OUTPUT 1	generic fault, the contact changes position when the load is no more supplied as a result of a fault in the inverter stage or after overload.
4,5,6	RL 2	OUTPUT 2	Battery discharging, the contact changes position when the load is powered from the battery due to a mains power failure
7,8,9	RL 3	OUTPUT 3	End of battery discharge, the contact changes position when, during a mains outage, the remaining time for battery discharge has reached the minimum value defined. Once this time has passed, the load will remain unpowered (the factory-set end of discharge pre-alarm value is 5 minutes)
10	+12V	POWER	Power supply +12Vdc 80mA (max.) [pins 10 and 11]
11	GND	POWER	
12	IN 1	INPUT 1	Inverter OFF. Connect pin 11 to pin 12 (for at least 2 seconds). If the INVERTER OFF command is received, the FC switches off the inverter removing power to the load
13,14	EPO	INPUT EPO	The FC is factory-fitted with the EPO terminals short circuited. If a remote EPO must be activated, remove the jumper and connect the external push button (NC contacts). The FC can be shut down in hazardous situation from a remote position simply by pressing a button.

Warning	
	If only the mains power supply is removed, for example by opening the switch of the power supply panel, as a means for shut down the FC in an emergency the FC will keep the load powered using the energy stored in the batteries.

Set of contacts: The functions of RL1, RL2, RL3 and the input command (IN 1) are factory -set. They can be reprogrammed via display panel. The contacts position as shown is without alarms presents.

Note: **relays contacts rating is 24Vac - 1A.**

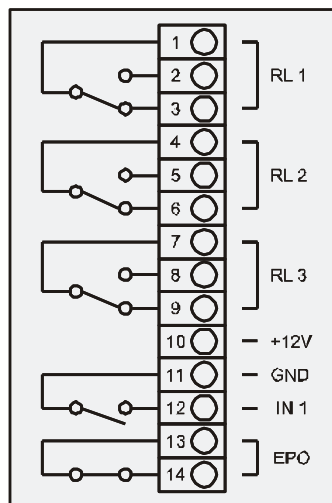

Figure 7- Remote alarm relay contact

1.1.7 RS232



SELV CIRCUIT PROVIDED. CONNECT TO SELV CIRCUIT ONLY.

(2) DB9 connectors are available for RS232 connection. The factory-set transmission protocol is as following:

Baud rate	Parity		Data bits	Stop bit
9600	NO		8	1
Length cable (meters)	50	100	200	300
Baud rate	9600	4800	2400	1200

Note: The BAUD RATE range [1200 – 9600], can be changed by the menu from CONTROL PANEL. The recommended values are as in the table

See the diagrams below for the connection procedure.

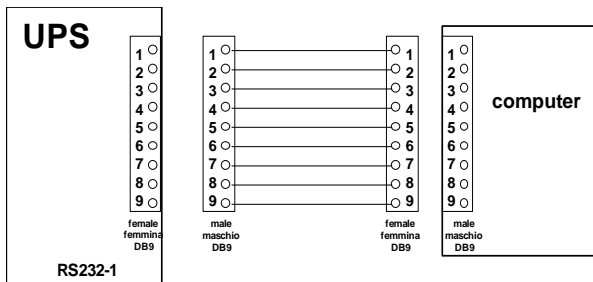

For connection with a computer, use a standard RS 232 cable. See the diagram for connection with a modem.

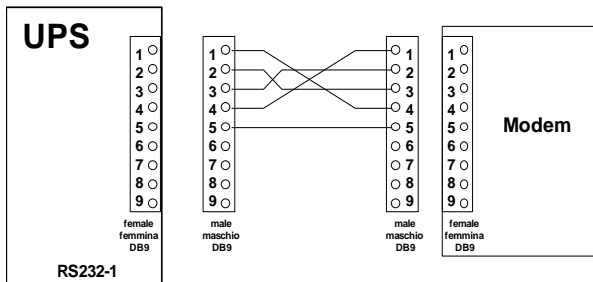
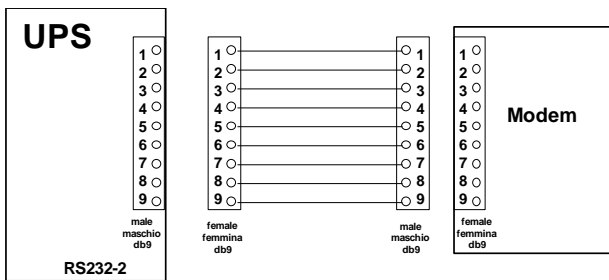

Figure 8- - DB9 female RS232-1



For connection with a modem use a cable standard. See the diagram for connection with a modem.

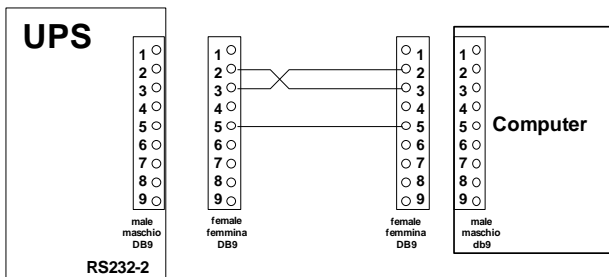

Figure 9- DB9 female RS232-2

1.1.8 SLOT 1 and SLOT 2

following cards may be inserted (optional):

NetMan (on SLOT 1 main or SLOT 2 aux)



SELV CIRCUIT PROVIDED. CONNECT TO SELV CIRCUIT ONLY.

Device for management of the FC's on the Ethernet. It can send information on the status of the device with different protocols:

Type	Description
TCP/IP UDP	compatible with Watch&Save
SNMP	for communications with NMS or with PowerNETGuard
HTTP	to display the status with a browser
TFTP	to configure or update the device when connected to the network

The main function of this device is to integrate the FC into the LAN network ensuring a high level of reliability of communication with the server to enable full management and control of the FC.

- MULTICOM card (SLOT 1 main; SLOT 2 aux)

This device may be used to:

- add a serial port to the FC;
- monitor the FC using MODBUS/JBUS protocol on RS485 or PROFIBUS (Multicom 401)

Note: each card connected precludes the use of a standard RS232 port, as follows.

The use of SLOT 1 (main) inhibits the use of RS232-2

The use of SLOT 2 (aux) inhibits the use of RS232-1



For the full and updated list of communication accessories, please visit the website www.riello-ups.com.

1.1.9 Remote alarms (optional cards)



SELV CIRCUIT PROVIDED. CONNECT TO SELV CIRCUIT ONLY.

6 output (relays): Form C dry contacts for alarms, rating 30 VAC/DC, 1A max, (programmable by display panel), 2 inputs (programmable by display panel) and 1x12V DC 100mA max auxiliary input.

1.1.10 Modem (optional)

Model compatible with the communication standards between the FC and the software provided.

Note: the modem must be connected to an RS232 port (D and E), a standard RS232 port may not therefore be used.

1.1.11 Multi I / O (optional)

The function of this accessory is to convert external signals from the FC (e.g. temperature of environment, temperature of battery premises, etc.) into signals by means of relay contacts or via serial output RS485 in MODBUS protocol.

It has the following characteristics:

- 8 inputs (e.g. humidity, smoke, etc. sensors)
- Communication with the FC via serial port
- 8 relays configurable with 8 events on the FC
- RS232 output port with configurable messages
- RS485 output port MODBUS /JBUS with configurable messages.

1.1.12 Battery temperature sensor (optional)

The FC has a connector for connection of the kit, which consists of a sensor to be placed inside the battery cabinet. The use of the temperature sensor allows the FC control logic to adjust the values of the charge and voltage according to the working temperature of the battery.

1.1.13 Battery temperature alarm (optional)

The battery temperature alarm is active only when battery temperature sensor is connected. The temperature threshold alarm can be changed with the following procedure:

- 1) This sequence of numbers must be entered into the display to access settings. Press the front panel buttons 3, 5, 151515 and 7
- 2) Press 3, 5, 327171, 7 to access the battery temperature settings
- 3) Press key 5 or 6 as necessary to adjust the minimum battery temperature [default:0 ; range:0-10]
- 4) Press key 7 or 8 as necessary to adjust the maximum battery temperature [default:50 ; range 20-60]
- 5) Press 1 to exit from the battery temperature menu
- 6) The alarm temperature value is now adjusted

1.1.14 Multi Panel

The Multi Panel is used to monitor the FC from a distance and provides a detailed overview of the module operating status. It allows the operator to consult measurements relating to mains power, output load, batteries, etc. and also to identify any malfunctions.

The Multi Panel connects from the FC Serial port on the Multi Panel to the RS232-1 or RS232-2 port in the FC

1.1.15 Start-up

1.1.15.1 Before starting up procedure

- Check all the input/output terminals are securely tightened;
- Check all the fuse holders have the fuse inserted, and are in the closed position;
- Check the ground conductor is connected (yellow/green cable);
- Check the polarity of the battery connections.

1.1.16 Start up procedure

Caution	
	DO NOT CLOSE BATTERY DISCONNECT UNTIL INSTRUCTED TO DO SO

- 1) close input power switch SWIN,
- 2) On front panel, press button 1 twice, select the language and then press button 8 to return to the basic menu,
- 3) after a few seconds, messages on the status of the FC will start to be shown on the first line of the display panel; these will include the following message relating to the battery disconnect:
- 4) close the output switch SWOUT. Once this operation is carried out, fans start to run.

caution	
	When this message is shown on the display panel: BATTERY CHARGE OFF Then close the battery disconnect /switch

1.1.16.1 Multiple battery disconnect

If multiple battery cabinets are present, all breakers must be closed within one minute after the **BATTERY CHARGE OFF** message disappears.

If this time constraint is a problem, do the following:

- 1) Disable the automatic battery test by pressing button 3 then 5 on the control panel, followed by entering the code 323232.
- 2) Close all the battery cabinet circuit breakers
- 3) Re-enter the code 323232 to enable the battery test.

Configure the value of the battery capacity according to the instructions in section **1.1.31.2 “Customizing”**.

After the start-up operations have been completed, perform a manual battery test:

- 1) Press button 3 and then 2 on the control panel.
- 2) At the end of the test, after about 8 seconds, with the FC started correctly and with the battery connected, on the signals and control panel, the two green input and output LED's must be steady light .

Once the FC has been installed, check that the message NORMAL OPERATION appears on the first line of the display panel.

1.1.17 Single FC and load shutdown

This operation will shut down the load connected to the output. In parallel version each procedure must be carried out on all the FC's.

- 1) Open the load switch
- 2) Open SWOUT, output switch.
- 3) Open SWIN, input switch
- 4) Open battery switch / disconnect or circuit breaker



The load is no longer powered and after a few seconds the FC display panel will also shut down. Neutral is not interrupted by the FC (the input neutral is also present at the FC output). Follow the instructions in section Start-up (section 1.1.15) procedures to restart FC.

Control Panel and Display

Signal panel functions

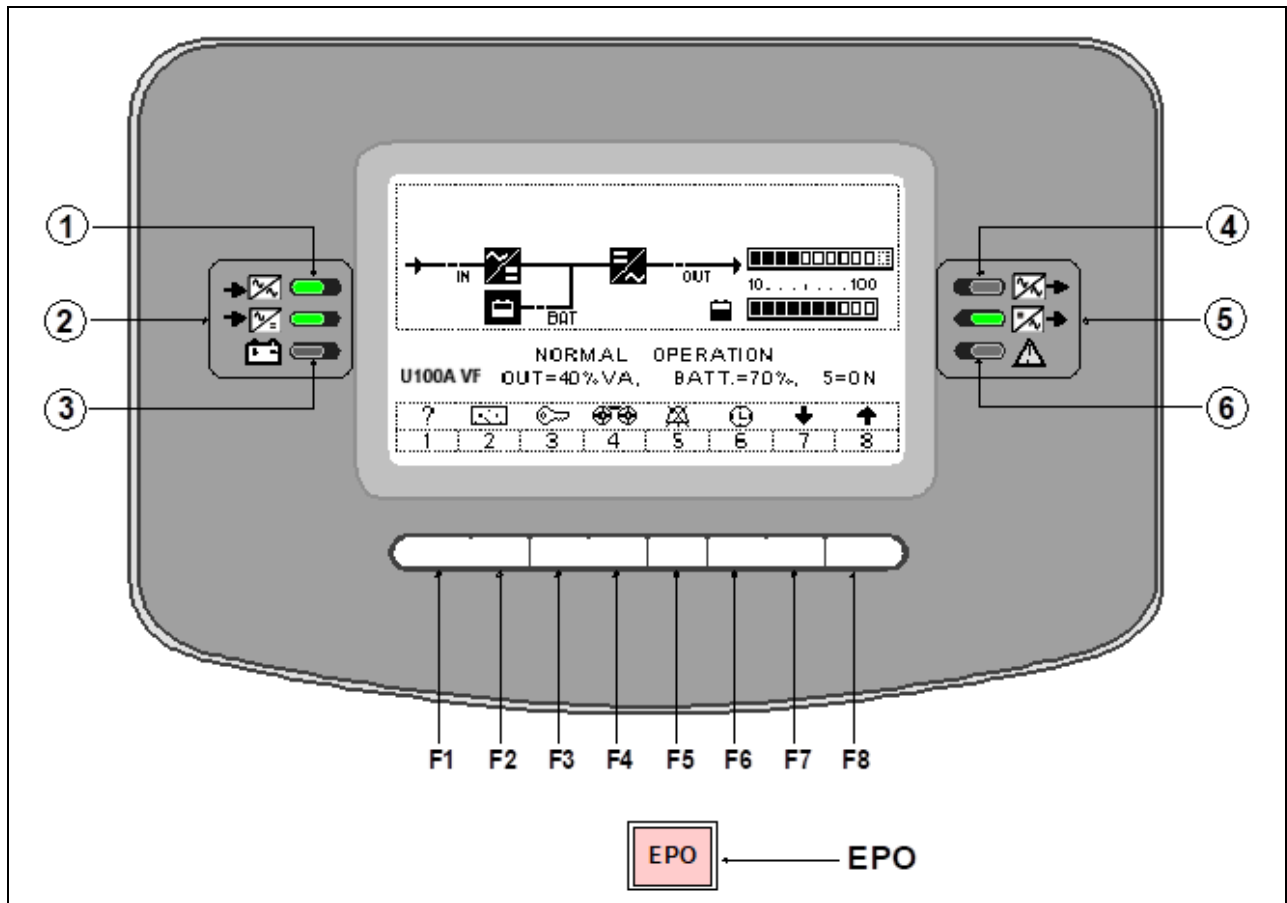







Figure 10- Control panel and display

F1, F2, F3, F4, F5, F6, F7, F8 = FUNCTION KEYS. The function of each key is shown at the bottom of the display and it varies according to the menu.

EPO = Emergency Power Off button.

Table 4- Led status indicators

Led status indicators					
Indicator	Symbol	Color	Function	State	Meaning
①		N.A.	N.A.	N.A.	NOT USED
②		Green	Mains line indicator	On	Mains is present and correct
				Flashing	Mains is present but not correct
				Off	Mains is not present
③		Yellow	Battery powering the load	On	Load on battery
				Flashing	"LOW VOLTAGE ON BATTERY PRE-ALARM" is active, or BATTERY DISCHARGE or SWB OPEN alarm is active
				Off	When the battery is not supplying the load
④		N.A.	N.A.	N.A.	NOT USED
⑤		Green	Normal output	On	load on inverter or stand-by operation, the output power is correct (< 100%VA) and SWOUT is closed
				Flashing	Load switched onto inverter, the output power > 100%VA, or switch SWMB is closed
				Off	Load is switched onto automatic bypass, or SWOUT is open.
⑥		Red	Alarm for internal fault	On	Internal fault is present
				Flashing	-
				Off	There are no internal faults.

Graphic display

A wide graphic display is present on the FC door, which allows the user to have a close-up, detailed overview in real time of the status of the FC. The user can switch the FC on and off, check electrical mains, output, battery measurements etc. ⁽¹⁾ and perform the main unit settings.

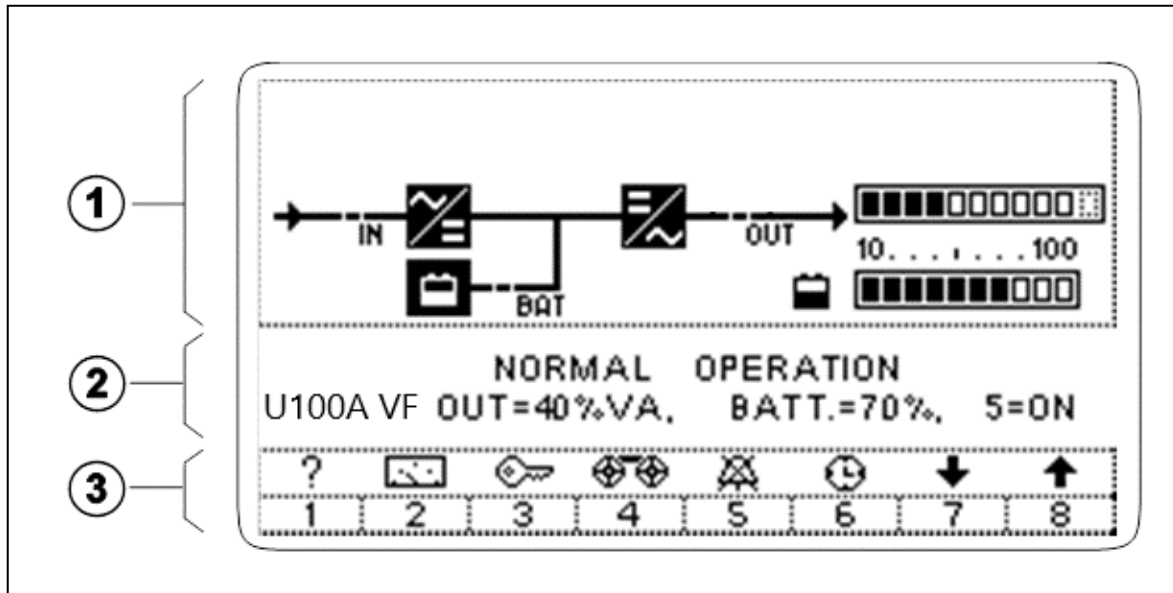

Figure 11- Graphic display

Description of the Display

- ① Operation Diagram** Area of the display where the FC status of operation is shown by means of shapes with filled lines when they are active and with dotted lines when they are inactive.
- ② FC MESSAGES AND MAIN OPERATING VALUES.** Area where the FC operating status is displayed by means of two text lines. The first line displays messages that are explained in the “alarm message” paragraph”. The second line displays the main operating values about system, output load, battery, buzzer and alarm message number.
- ③ KEY FUNCTION** Area that shows the key function by means of numbers and icons. The key function is also indicated in the sub menus, on the two text lines with the related number. When a key is pressed the related box change to filled line



¹⁾ The precision of the measurements is: 1% for voltage measurements, 3% for current measurements, 0.1% for frequency measurements. The indication of residual autonomy time is only an ESTIMATE; it must not, therefore, be considered a precise measuring instrument.

Table 5- Diagram item shapes

diagram items shapes		
Active	Inactive	Meaning
		Input converter
		Output inverter
		Bypass line switch
		Battery
		Manual bypass line switch
		Bypass line input switch
		Battery switch
		Output switch
		Main line input switch
		Output load (40% VA or 0% VA)
		Battery (70% Ah or 0% Ah)

Table 6- keys numbers and icons

keys numbers and Icons			
Key	Off/ON	Icon	Meaning
			Information or n. 1
			Measures or n. 2
			Commands or n. 3
			History or n. 4
			Buzzer OFF/ON or n. 5
			Display date/hours or. n. 6
			Decrease value or sub menu or n. 7
			Increase value or previous menu or n. 8

1.1.18 Basic menu (text lines area)

If no commands have been inserted, the first text line shows messages to inform about status of operation.

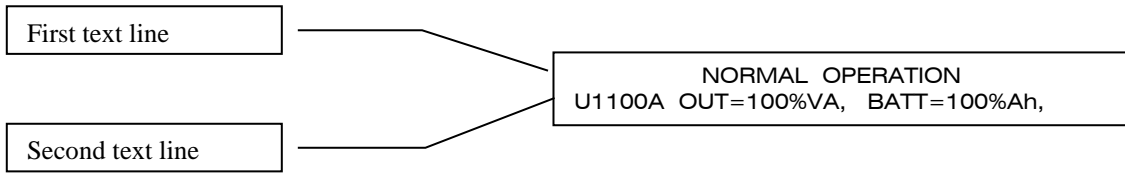

 In each operating condition, the display returns to the "basic menu" after two minutes from the last command inserted with the keys. The basic menu shows the signal messages relating to the current operating state.

1.1.19 The first line of the basic menu

When there are no alarms present, the first text line of the main menu shows a fixed message, **"NORMAL OPERATION"**

NORMAL OPERATION
U100A VF OUT=100%VA, BATT=100%Ah, 5=ON

When some alarms are present, the first text line of the main menu shows each active **ALARM MESSAGE**, one at a time for a few seconds:

ALARM MESSAGES
U100A VF OUT=100%VA, BATT=100%Ah, 5=ON

1.1.20 The second line of the basic menu

The second line displays the main operating values about system, output load, battery, buzzer and alarm message number

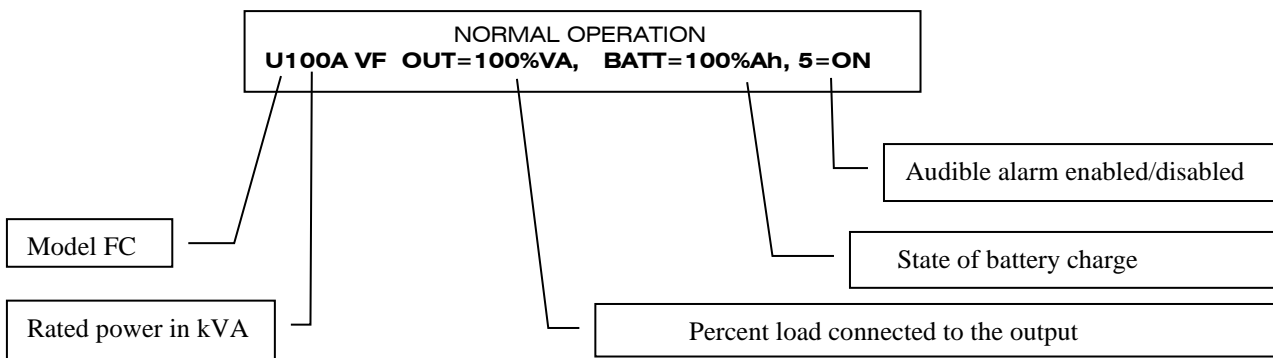

- **U100A VF** indicates an FC model with 100kVA rated power, operating with 50Hz output frequency. When the unit is set for the parallel operation the letter "P" is added (U125AP). The letter "P" became lower case "p" when the unit operate as slave.

- **100%VA** provided in the example is obtained with the measurement of the output current. The number indicates the output current in percentage of the rated value. The percentage value showed is the greater of the rms and peak current between the three phases.
- **BATT= 100%Ah** example of the percentage of the capacity of battery recharge. The value 100%Ah is obtained with the measurement of the current and time in recharge mode. The number indicates the % of the capacity of the battery connected during recharge operation. The system automatically remains in fast charging for all the time needed to supply the battery with the quantity of charge lost during discharge mode.
- **%Ah** changes to "min." (minutes) during operation in the event of a mains failure or when the battery is discharging . In this latter case the numeric value refers to the remaining minutes of operation, calculated according to the discharge current and to the state of charge of the battery. The backup time shown is calculated according to the discharge current present at that time, the stored value of the capacity of the battery connected and the stored value of the percentage of recharge prior to discharge. The backup time shown should not be considered as indicative due to the many different factors affecting it. If considerable differences are noted between the expected value and the actual time of a discharge with constant load, the stored data of the battery must be checked and the state of the battery as well.
- **5=ON** example of the message showing the audible alarm is enabled. If disabled, the message changes to **5=OFF**.

1.1.21 Language setting menu (keys 1, 1)

From the keys menu, press **1** twice to access the languages menu.
The following languages are available:

- | | |
|-----------|--------------|
| ○ Italian | ○ Polish |
| ○ English | ○ Hungarian |
| ○ French | ○ Turkish |
| ○ German | ○ Czech |
| ○ Spanish | ○ Russian |
| ○ Dutch | ○ Romanian |
| ○ Swedish | ○ Portuguese |

The system will show all subsequent messages in the language selected . The selected language remains stored even after the shutdown and restart of the system. The current language can only be changed by accessing the LANGUAGES menu.

Use keys **1** and **8** to return to the basic menu.

1.1.22 Measurements menu (key 2)

The measurements with two line displayed, are selected from the basic menu by pressing key **2**

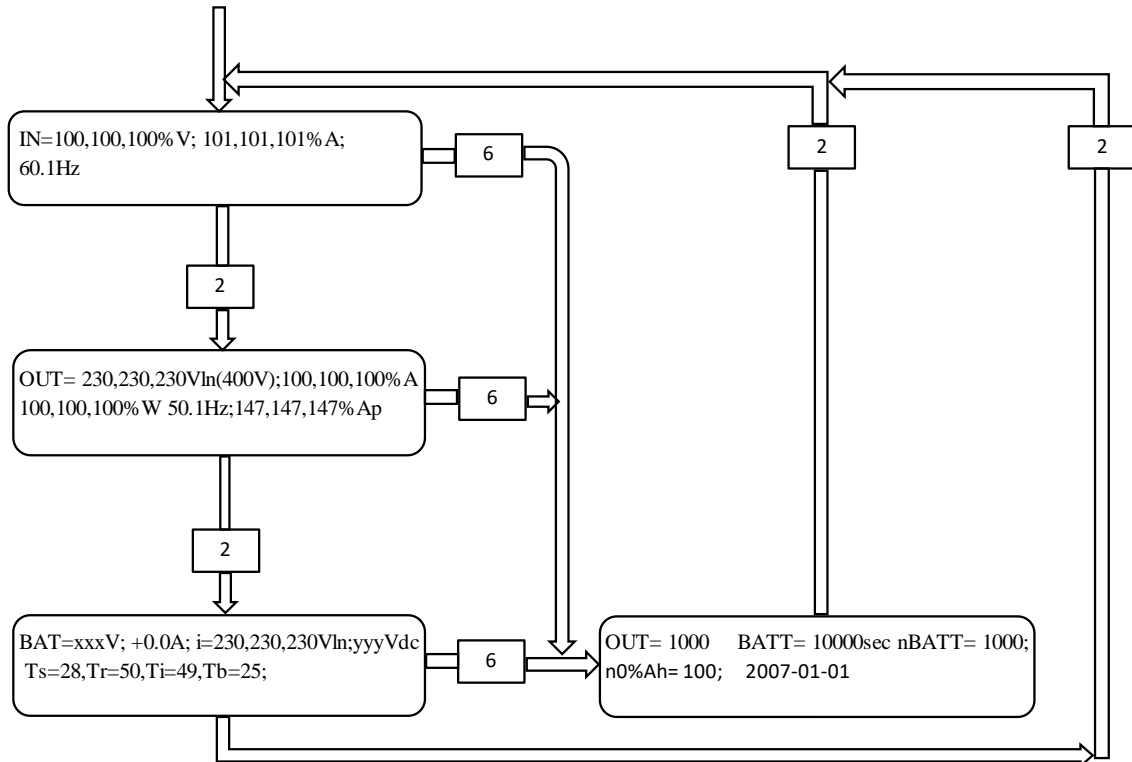

IN

- **IN=100,100,100%V, 60.2Hz** Measurement of the three L-N voltages as a percentage of the rated value and input frequency. For example 100% is equivalent to 277V.

- **101,101,101%A** Measurement of the three input currents as percentage of the rated value.

Out

- **OUT=230,230,230Vln** Measurement of the three output L-N voltages of the FC. In bracket the L-L value.

- **100,100,100%A** Measurement of the three output currents as percentage of the rated value.

- **100,100,100%W** Measurement of the real output power as percentage of the rated value.

- **50.1Hz** Output frequency.

- **147,147,147%Ap** Measurement of the peak currents as percentage of the output currents during operation from inverter.

Batt

- **BATT=xxxV** Battery voltage value;

- **+0.0A** Battery current, positive when Battery discharging, negative when battery charging

- **i=230,230,230Vln** Inverter output L-N voltage

- **yyyVdc** Input inverter DC voltage (DC link voltage)

- **Ts=28, Tr=50, Ti=49, Tb=25;** Ts= temperature inside cabinet, Tr= temperature of the rectifier module, Ti= temperature of inverter module. Tb= Temperature of the battery cabinet, only when external probe is installed.

Batt Out

- **OUT=10000h** Hours of normal operation

- **BATT=10000sec** Time period when in battery mode

- **nBATT = 1000** indicate the number of times the battery has been discharged

- **n0%Ah = 100** indicate the number of times the battery has been fully discharged

- **2007-01-01** Date stored on first start-up of the FC. These are HISTORY data, and remain stored even when the device is switched off and may not be reset.

1.1.23 Full page Measurements and output waveforms (key 2,7)

The full-page measurements and output voltage and current waveform are selected by pressing key 7 from the two line measurement menu.

Basic Menu

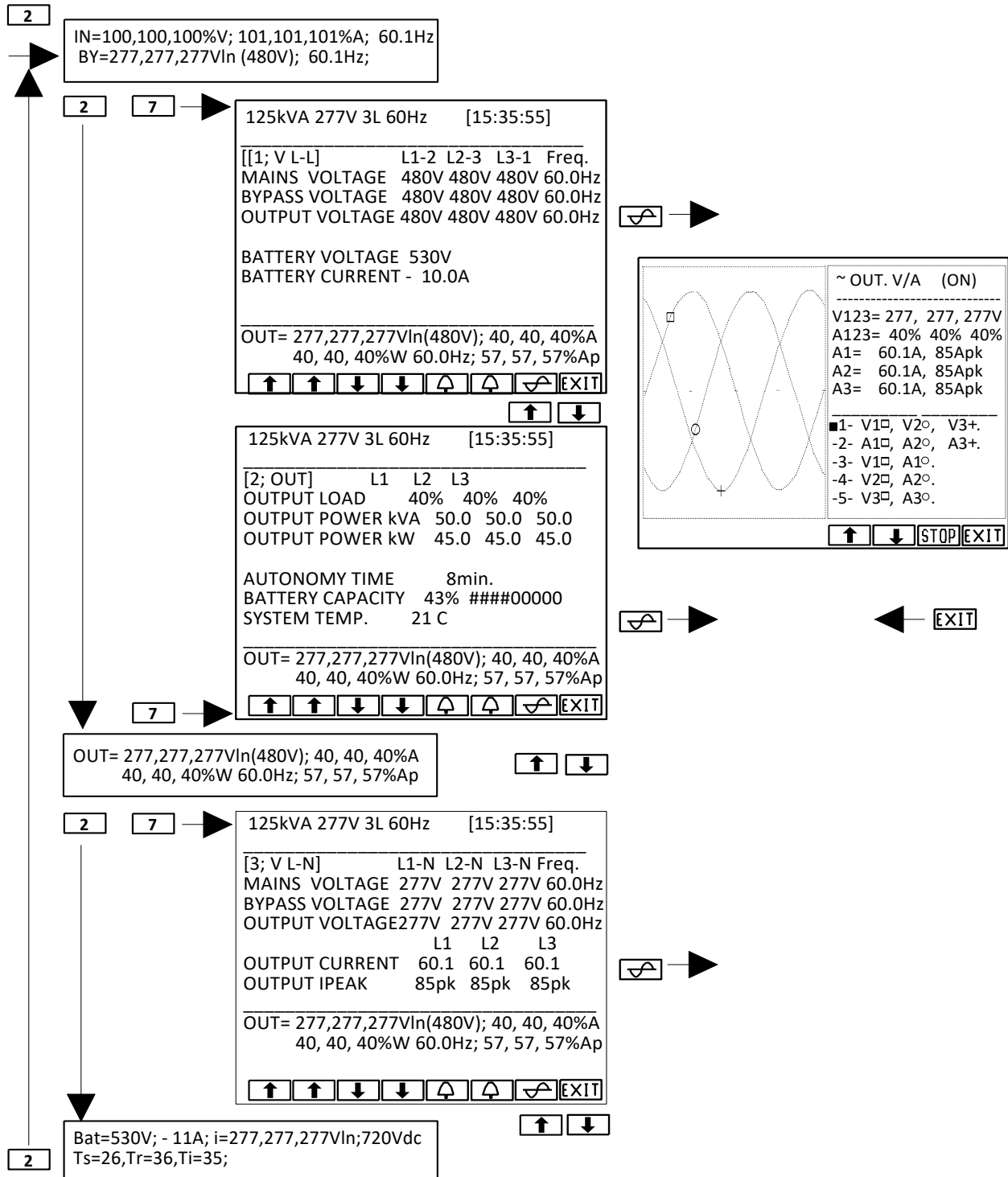

1.1.24 Controls Menu (key 3),

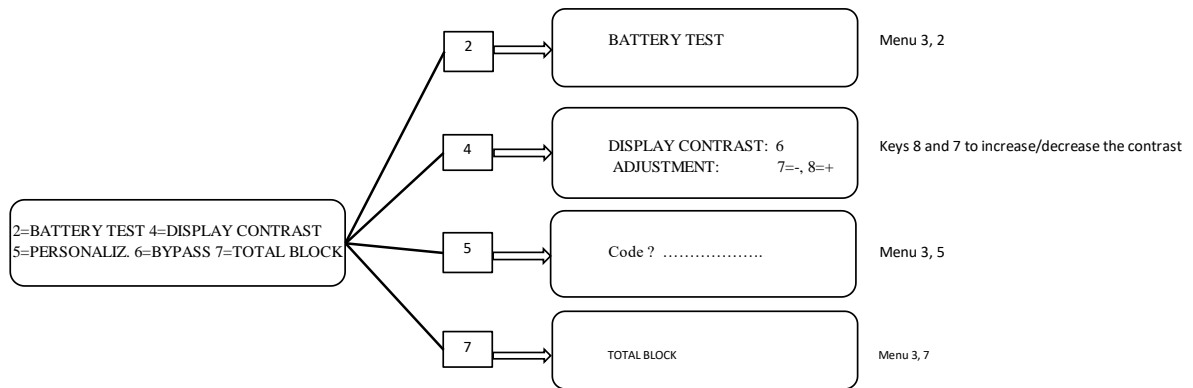

1.1.24.1 Keys menu 3, 2: battery test

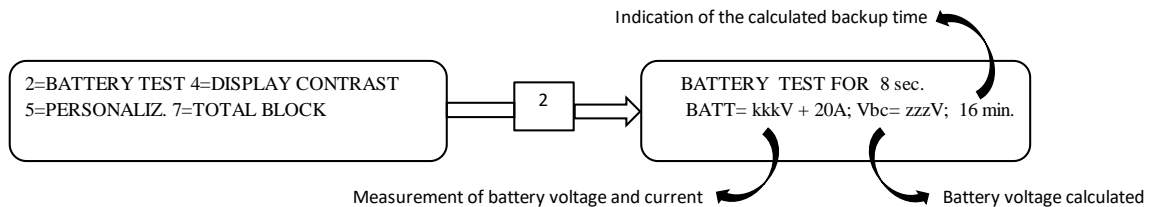

This activates the cycle to check the state of efficiency of the battery, which lasts 8 seconds.

i Press key 8 to interrupt the test and return to the basic menu before this time has elapsed.

The battery test cycle lowers the rectifier output voltage so that the battery can be evaluated with the load even when the power supply voltage is present.

The battery test cycle is activated:

- manually;
- automatically every 60 sec. after each failed test (for three times), or each time the system is restarted;
- automatically every 24 hours from system start-up;
- automatically in no visible mode during operation without mains power supply.

At the end of each test, the alarm is activated if the voltage measured is lower than the calculated voltage; the charge value stored, and the backup time indicated are subsequently halved. A new test is performed 60 sec. after activation of the alarm and if the result is negative the alarm is activated once again for another 60 sec.

The alarms continue to halve the charge value stored until the calculated battery voltage is less than the voltage measured. This battery control system produces an alarm each time the battery is seen to have less than half of the expected charge.

- If this alarm is on PERMANENT, it indicates that the battery capacity is low, the battery circuit is interrupted, the battery disconnect has remained open or one of the protection device fuses has been triggered.
- If this alarm is on TEMPORARY, it indicates a reduction in the capacity of the battery; the more frequent the alarm, the more serious the problem.

i **Note for Disabling BATTERY TEST**

- press keys 3, 5: “CUSTOMIZING”;
- insert code 323232, with battery test disabled the code o=02 will be shown in the basic menu of the display.
- To reactivate the test, insert code 323232 again.

1.1.24.2 Customizing

The "CUSTOMIZING" menu is accessed by means of key 5 from the COMMANDS menu; an intermediate menu will then be displayed in which a CODE has to be entered.



Access by CODE ensures that unauthorized persons cannot modify the operating parameters of the equipment.

The use of the codes to modify the operation of the equipment (such as the frequency converter, stabilizer, rectifier start-up delay, etc.) are the prerogative of the service personnel.

The activated codes may be displayed (if present) with the following sequence of keys from the basic menu: 7 + 4 then by scrolling through the alarms with keys 7 and 8.

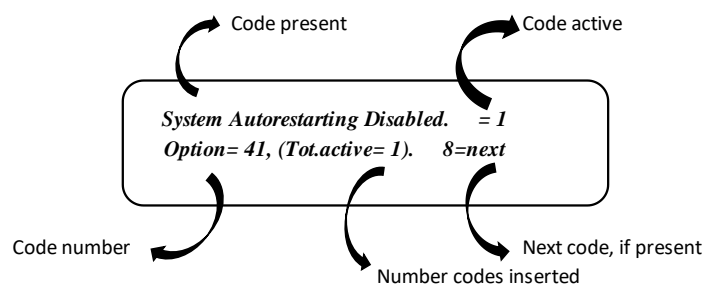

1.1.24.3 Entering customized codes

Keys menu 3, 5: CODE 436215

The code is no longer required for 2 minutes after it has previously been inserted.

The next menu can only be accessed by inserting the correct code, otherwise it returns to the basic menu.

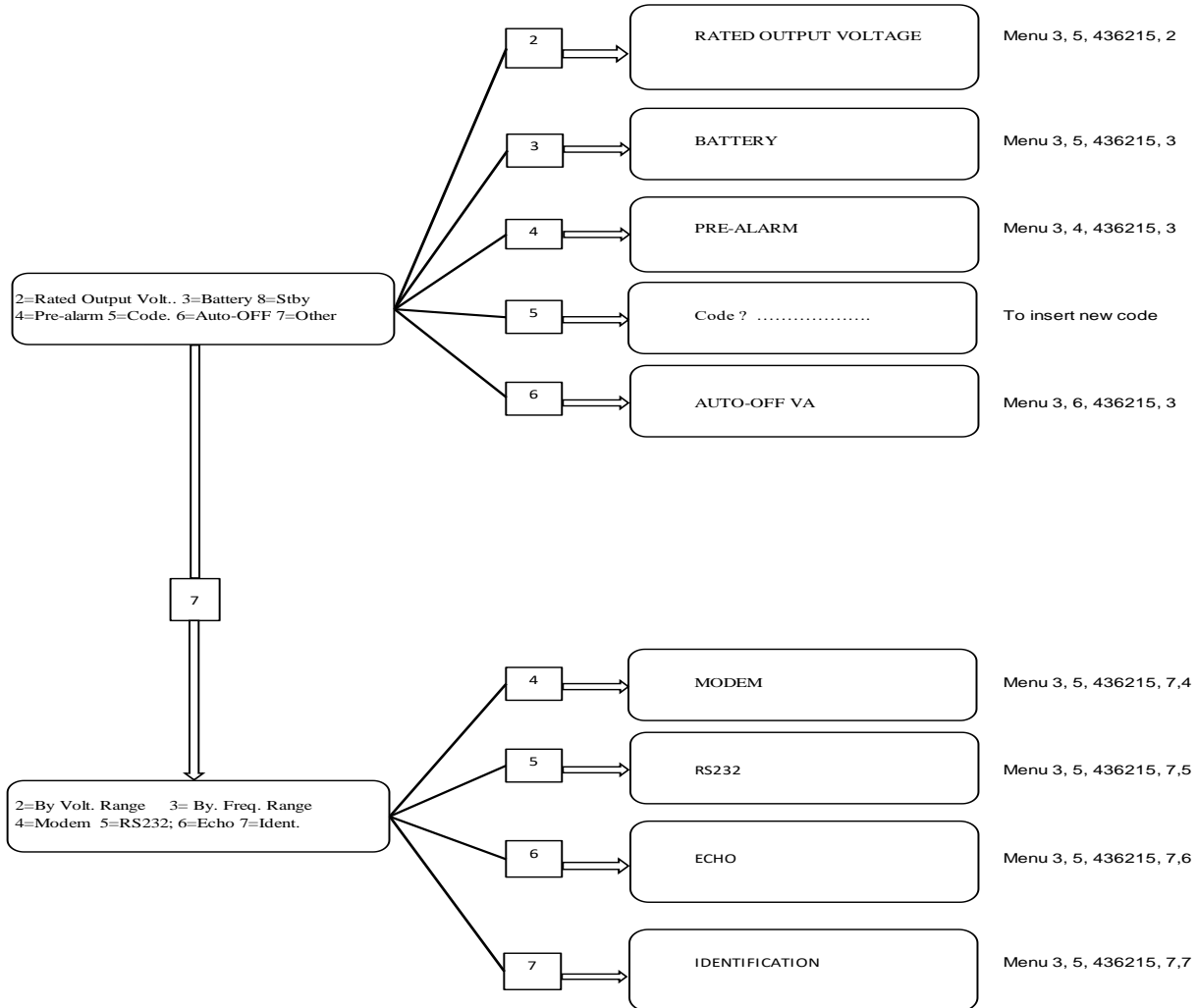

1.1.24.4 Rated output voltage.

Press the following sequence of keys to access the menu:

- Press 3,
- press 5,
- Enter code 436215,
- Then press 2

Keys 7 and 8 can be used to decrease/increase the rated output voltage.

The value displayed is the phase voltage L-N.

The value set modifies the operation of the inverter, during normal operation.

1.1.24.5 Battery

Press the following sequence of keys to access the menu:

- Press 3,
- press 5,
- Enter code 436215,
- Then press 3

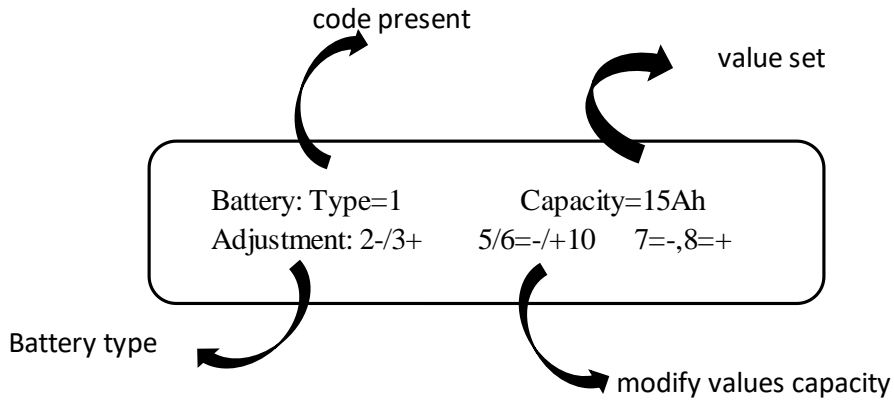

On initial installation the rated capacity value of the connected battery must be inserted; this value is usually printed on the battery container.

battery capacity

 It is important to insert the correct battery capacity value since it is used by the system logic to calculate the backup time. If not set otherwise, this value is assumed to be equal to the FC power. e.g.: at 100kVA the value set by default is 100Ah .

Battery type =

1. Default pre-set for normal batteries;
2. High intensity discharge batteries;
3. Wet cells also called vented or flooded batteries;

1.1.24.6 Cyclic battery recharging

Select type 1 or 2 and then press key 4 to display the pre-set voltage values:

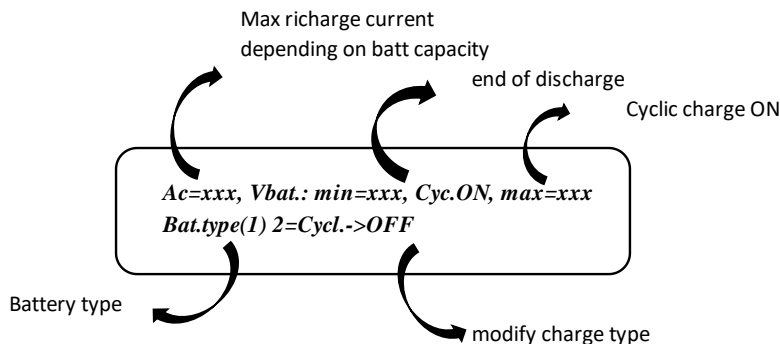

Select type 0 and then press key 4 to modify the voltage values reset by keys 3,4 and 7,8.

Ac=xxx, Vbat.: min=xxx, Cyc.ON, max=xxx
Bat.type(0) 2=Cy., 3-/4+ 7-/8+

1.1.24.7 Two-level recharging

This type of recharging has two steps or two levels (EN 50272-2); the first step include fast charging (U1) with limited current, while in the second step charging is with float voltage (U2).

 NOTE: this type of recharging may be configured on site and is mainly used for special type batteries such as vented and Ni-Cd.

For batteries of type 1, 2 or 3, press key 2 from menu to change from cyclical charge to charging at two levels

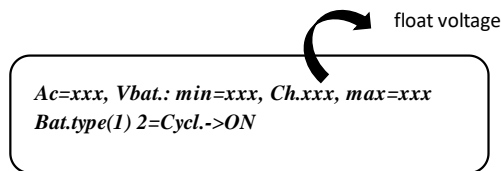

For batteries of type 0, press key 2 from menu to change from *cyclical charge to charging at two levels*

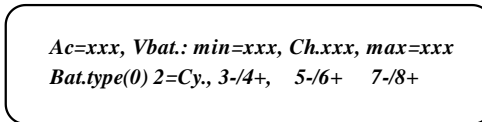

Use keys 3,4; 5,6 and 7,8 to set the values

1.1.24.8 PRE-ALARM

Press the following sequence of keys to access the menu:

- Press 3,
- press 5,
- Enter code 436215,
- Then press 4

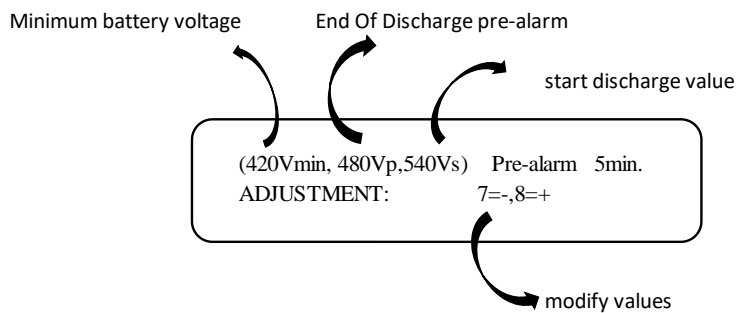

Press key 1 to exit the menu.

The menu above will appear with batteries of type 1, 2 or 3.

- Voltage values Vmin, Vp and Vs are not fixed values but are a function of the battery discharge current, [Vp= Vmin+5V+10*(battery current [A]/battery capacity [Ah]).
- Keys 7 and 8 are used to decrease/increase the time to activate the pre-alarm before the system blocks due to end of battery discharge. Steps of 1 minute are possible from 2 to 254 minutes.
- The pre-alarm signal is activated when the remaining calculated time is lower than the pre-alarm value set or when the battery voltage is lower than the pre-alarm voltage value Vp.

Pre-alarm

 A wide safety margin must be provided for the use of the pre-alarm function, since the expected backup time may not provide for increases in the output load power, and may not make allowance for sudden, unexpected battery defects.

Type "0" Battery

With the battery set to type 0, the following menu is displayed:

(420Vmin,480Vp,540Vs) Pre-alarm : 5min
Adjustment: (4=setV), 7=-,8=+

When key 4 is pressed, the program proposes the setting of the three voltage values.

Vbat.test: Vmin., Vp, Vs: 420, 480, 540V
Adjustment: 3-4+, 5-6+, 7-8+

Preset value

 With the three factory preset voltage values, the display panel may indicate an incorrect backup time during discharge.

Battery type "0" setting

The three values to be set are linked to the **battery discharge rate** (relationship between discharge current / battery capacity in Ah).

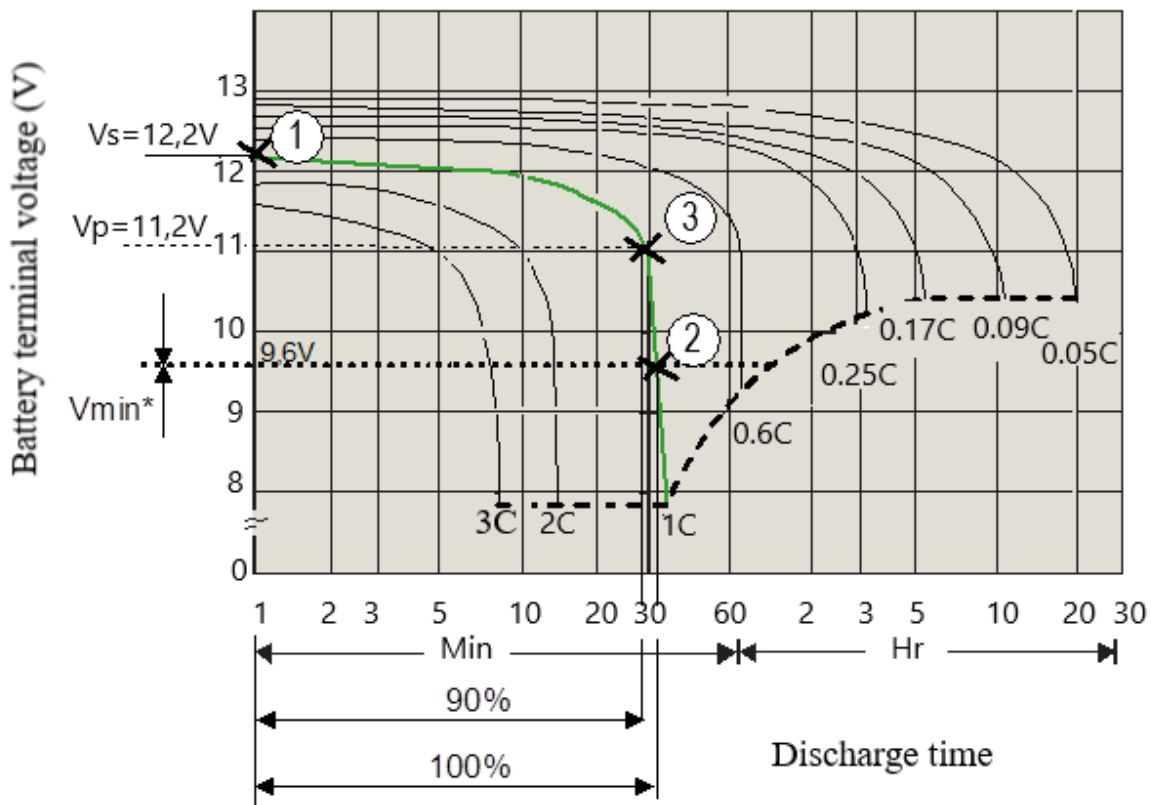

Example: for a 100Ah battery with a discharge current of 100A, the rate is 1.

The three values, Vs, Vmin and Vp, are obtained from the discharge characteristic curve, supplied from manufacturer, relating to the **battery discharge rate** 1C has been determined:

- Vs start of discharge voltage (1), intersection with the x-axis (battery terminal axis), [the value must be multiplied for 40, number of batteries]
- Vmin minimum voltage value (end of discharge battery), point of intersection with the dashed curve (if this value is lower than Vmin* set up Vmin=Vmin* (2). [the value must be multiplied for 40, number of batteries]
- Vp battery voltage with discharge at 90% of the total time (3).

1.1.24.9 AUTO-OFF Timer.

Press the following sequence of keys to access the menu:

- Press 3,
- press 5,
- Enter code 436215,
- press 6
- then press 5

AUTO-OFF Timer: Toff > 0: 0', Ton = 0: 0'
ADJUSTMENT: (5=Toff, 6=Ton) 7=-, 8=+

Press key 1 to exit the menu.

The keys have the following functions:

- 6 to modify the value Ton
- 5 to modify the value Toff.

Toff and Ton are time values used by the system to affect an automatic daily shutdown and restart cycle.

The timer cycle is inhibited when Toff = Ton.

When the internal clock reaches the time Toff, if the mains voltage is present and the percentage of recharge is less than 60%, only the following is displayed:

AUTO-OFF Timer: Toff = 20:00', Ton = 7:00'
H100, OUT100% BATT = 50%Ah 5=ON

The system waits until the battery recharge exceeds the value of 60% before deactivating.

When the internal clock reaches the time Toff (20:00'), if the mains voltage is present and the percentage of recharge is greater than 60%, or the mains voltage is not present and operation is from battery, the following is displayed:

AUTO-OFF Timer: Toff = 20:00', Ton = 7:00'
H100, OUT100% OFF:4 min 5=ON

The "end of discharge pre-alarm" contact for remote alarms is also switched.

In this case the system remains active for the next 4 minutes, after which the system switches onto the bypass line and then deactivates.

There is no output voltage after deactivation



The interval between the start of the alarm and deactivation is equal to the interval selected as PRE-ALARM. When the internal clock reaches the time Ton (7:00'), if the mains voltage is present, the system automatically reactivates and returns to normal operation.

1.1.24.10 Modem set-up

Press the following sequence of keys to access the menu:

- Press 3,
- press 5,
- Enter code 436215,
- press 7
- then press 4

MODEM enable = 0,
ADJUSTMENT: (5=dial, 6=send) 7=-, 8=+

Press key 1 to exit from menu.

Keys 7 and 8 are used to decrease/increase the control value for management of the modem. The choice is between the values of 0 to 5. The initial value is 0.

- **0** = the modem connected to the RS232 port is deactivated. Terminal 20 of the RS232 connector assumes a low level (-12V) (DTR signal deactivated).

MODEM=0



NOTE: the configuration MODEM=0 is essential when the modem is not used, and the RS232 connector is used for connection to the remote panel

- 1= signal DTR is activated (terminal 20 at +12V), the modem is enabled to reply (it should be remembered that a remote panel connected to the RS232 connector in place of the modem remains off).
- 2= signal DTR is activated, the modem is ready to reply and for automatic calls.
After an "internal fault" alarm has been on for 30 seconds, the system automatically dials the stored "DIAL" number. When it receives the modem's receiving reply it sends a message made up of the FC acronym, the stored "SEND" number, a copy of the text shown on the display, the alarm code and the date and time of transmission.

"HAYES" type commands



NOTE: for correct operation, use a modem that has already been configured to recognize "HAYES" type commands and that is able to dial the phone number using pulses or tones as required by the phone line that is to be used.

If the phone line is engaged or the remote modem does not reply, the system recall again every 5 minutes until it manages to connect, provided that the alarm condition is still present.

- 3= Same as 2 with automatic call when any alarm is verified.
- 4= Same as 2 with automatic call only for alarm 10, and with sending of message only after the reply from the remote modem has been acknowledged by the reception of the character "}".
This mode ensures that the receiving computer does not lose any messages.
- 5= Same as 4 with automatic call when any alarm is verified.

1.1.24.11 "dial/send" modem

Press the following sequence of keys to access the menu:

- Press 3,
- press 5,
- Enter code 436215,
- press 7
- press 4
- then press 5(6)

*MODEM dial n.=6543210///////// <=2..3=>
ADJUSTMENT: (5=dial, 6=send) 7=-, 8=+*

Press key 1 to exit the menu.

Keys 7 and 8 are used to decrease/increase the figure on which the cursor is positioned. The cursor is moved by means of keys 2 and 3, and is indicated initially by the character '_'. Each number may assume values from 0 to 9, the symbol / indicates that the corresponding figure is disabled. A correct "dial" number must start with a figure from 0 to 9, the setting /6543210 is ignored. Select menu 35746 or press key 6 when menu 35745 is active to set the "send" number.

1.1.24.12 RS232

Press the following sequence of keys to access the menu:

- Press 3,
- press 5,
- Enter code 436215,
- press 7
- then press 5

Press key 1 to exit the menu. Keys 7 and 8 for RS232-1 (3 and 4 for RS232-2) are used to decrease/increase the baud rate. The choice is between the values 1200, 2400, 4800, 9600.

1.1.24.13 Echo

Press the following sequence of keys to access the menu:

- Press 3,
- press 5,
- Enter code 436215,
- press 7
- then press 6

Press key 1 to exit the menu.

Keys 7 and 8 are used to decrease/increase the number used to enable the "ECHO" function. The number may vary from 0 to 1 to disable or enable the function. When the function is enabled the system automatically sends a copy message of the display with the addition of the code "a=....." and the current date and time to the RS232 output. The message is sent for each variation in the state of the alarms (that is, any change in code a=.....).

1.1.24.14 Ident

Press the following sequence of keys to access the menu:

- Press 3,
- press 5,
- Enter code 436215,
- press 7
- then press 7

Press key 1 to exit the menu.

Keys 7 and 8 are used to decrease/increase the number used for the identification of a single unit in systems with several FC connected to a single RS232 serial line. The basic number is 0 and may be changed between values from 0 to 7.

1.1.24.15 Total block

Press the following sequence of keys to access the menu:

- Press 3,
- press 7,

*Total System Shut-OFF Command = 47263
WARNING, the Output Voltage will be OFF*

Exit the menu by pressing key 8 or any other key with a sequence other than the one described here. Pressing keys 4, 7, 2, 6, 3 in succession as shown on the display activates the command for TOTAL BLOCK of the system. When this command is active, the display shows the alarm

BLOCK COMMAND ACTIVE; 8=DEACTIV.

The command is executed after a few seconds' delay to allow for cancellation. This command is useful to achieve full deactivation in an emergency, operating remotely via the RS232 line. To reactivate the FC, press button 8.

 NOTE: To mask the command code 47263, insert code 436213 on the panel from the PERSONALIZATIONS menu (keys 3,5). Repeat the operation to display the code.

1.1.25 "Recorder": recorder events (key 4)

Press the following sequence of keys to access the menu: 4

*message alarm stored
a=FFFF-FFFF; 2005,12,31/14:45:50 n=100*

- Key 1: return to the basic menu.
- Key 2: activates the submenu "RECORDED VOLTAGES MEASUREMENTS".
- Keys 3, 4 and 5: keep their normal functions.

- Key 6: activates submenu 4, 6 "RECORDED CODES" and allows the exchange of stored alarm message with the display of the corresponding status codes at the time of the stored event, and vice versa. The status codes allow a more in-depth analysis by the trained personnel.

1.1.25.1 Recorded voltages measurements

Press the following sequence of keys to access the menu:

- Press 4,
- press 2,
- press 2,
- press 2,

```
IN=100,100,100%V,60.0Hz; BATT=430V,+100A
BY=400V,60.0Hz;n35 OUT=400,50.0Hz,100%
```

The "RECORDED VOLTAGES MEASUREMENTS" menu is accessed via key 2 (press 2 again to access the other measurement menus from menu 4 "RECORDED EVENTS" or menu 4, 6 "RECORDED CODES" only.

Press key 1 to return to the basic menu immediately.

In the example, n35 (flashing) indicates that the measurements shown refer to the state relating to recorded event number 35. The meaning of the measurements is the same as those in menu 2.

1.1.25.2 Recorded codes

Press the following sequence of keys to access the menu:

- Press 4,
- press 6,

```
s=FFFF c=FFFF b=FFFF r=FFFF-FF the=FFFF-FF
a=FFFF-FFFF; n=100, 1992,12,31/14:45:50
```

The "RECORDED CODES" menu is accessed with key 6 from menu 4 "RECORDED EVENTS" and menus 4, 2; 4, 2, 2; 4,2,2,2 that is the recorded measurement menus.

Return to the basic menu by means of key 1.

Apart from key 6, the other keys have the same functions as those described for menu 4, and the messages on the lower line also remain the same.

The upper line: s=FFFF c=FFFF b=FFFF r=FFFF-FF i=FFFF-FF, shows the internal codes recorded at the time of the event.

Use key 6 to return to menu 4 while keeping the current event; you can then switch several times from the description of the event with the "stored alarm message" to the one with the internal codes.

1.1.25.3 Recorded value on full page

The "RECORDED value on full page" menu is accessed with key 4 from menu 4.

On this page, when the "stop" key is not cross marked, are shown all present measurements and internal codes, and the past measurements when the "stop" key is marked.

When the "STOP" key is cross marked it is possible to look to the other past value recorded by arrow keys.

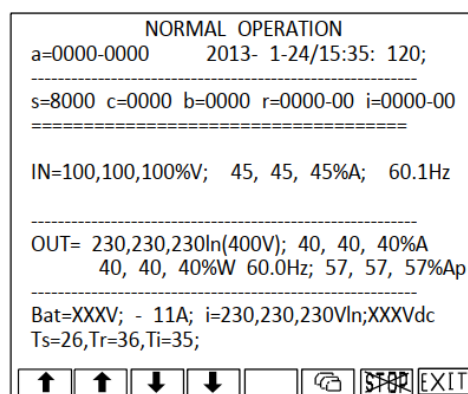
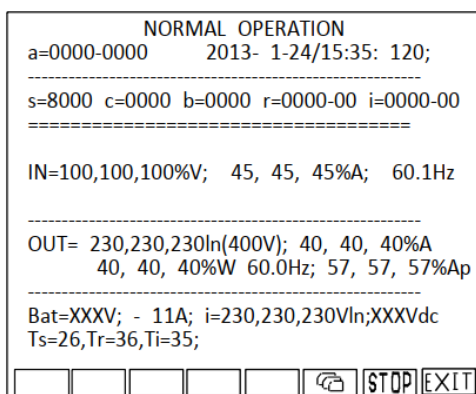









 This key switch to the page showing the message and codes of 4 past events and it is possible to look to the other past events by arrow keys.

```

NORMAL OPERATION
a=0000-0000      2011- 1-24/13:35: 0;n120
-----
PREALARM, LOW BATTERY VOLTAGE
a=1C00-0000      2011- 1-24/10: 1: 3;n119
-----
MAIN LINE VOLTAGE FAIL or SWIN OFF
a=1800-0000      2011- 1-24/10:05: 1;n118
-----
NORMAL OPERATION
a=0000-0000      2011- 1-24/10:01:18;n117
-----
MAIN LINE VOLTAGE FAIL or SWIN OFF
a=1800-0000      2011- 1-24/09:40: 1;n116









```











```

s=8000 c=0000 b=0000 r=0000-08 i=0000-00
a=0000-0000      2011- 1-24/13:35: 0;n120
-----
s=8000 c=0000 b=3C20 r=0000-08 i=0000-00
a=0400-0000      2011- 1-24/13: 5: 5;n119
-----
s=8000 c=0000 b=0000 r=F881-00 i=0000-00
a=1C00-0000      2011- 1-24/13: 1: 3;n118
-----
s=8000 c=0000 b=0000 r=F881-00 i=0000-00
a=1800-0000      2011- 1-24/12: 1: 1;n117
-----
s=8000 c=0000 b=0000 r=0000-08 i=0000-00
a=0000-0000      2011- 1-24/11: 4:18;n116

```

 This key switch to page with all codes and measurements displayed of 1 event. The key “6” switch from code with message line to full lines code.

1.1.26 Disabling the audible alarm (key 5)

Press the following sequence of keys to access the menu: 5

During operation from the basic menu, the operator can permanently disable or re-enable the audible alarm (buzzer) by pressing key 5. "5=ON" is shown in the basic menu when the audible alarm is enabled and "5=OFF" when the audible alarm is disabled. Key 5 in other menus may only be used to disable the sound, when no other functions are envisaged for this key. The command is stored even during a shutdown due to a power failure.

1.1.27 "Clock": date/time (key 6)

Press the following sequence of keys to access the menu: 6

The "DATE/TIME" menu is accessed via key 6 from the basic menu.

The display shows the current contents of the internal calendar and clock with the following format:

DATE/TIME = ymd/h = years, months, days / hours, minutes, seconds.

The contents can be modified via the menu by inserting the personalization code 436215. This code remains active for 2 minutes after it has been inserted.

The next menu can only be accessed by inserting the correct code, otherwise the system returns to the basic menu.

Press keys 2, 3, 4, 5 or 6 to select which value to change.

DATE/TIME = Xmg/h = 2003 12 31/24:60'60
ADJUSTMENT: 7=-, 8=+

In this case the year's value is to be changed; the flashing symbol X superimposed over the letter shows which field has been selected. Press keys 7 or 8 to decrease/increase the selected value by one unit; press any one of the other keys to exit the menu.

1.1.28 "Arrow down": Internal Codes, firmware ver.(key 7)

Press the following sequence of keys to access the menu: 7

s=FFFF c=FFFF b=FFFF r=FFFF-FF i=FFFF-FF
a=FFFF-FFFF; INTERNAL CODES; ver.10.....

The "INTERNAL CODES" menu is accessed from the basic menu via key 7. The codes represented provide information on the operating status of the FC and about system firmware version. This information is used by the service personnel.

Pressing more key 7 it is shown the page with information about other firmware version, serial number and service phone number.

125kVA 277V 3L 60Hz [15:35:55]

System: Ver.= 28, rev= 1, ck=A404
Panel: Ver.= 01, rev= 1, ck=B235
DSP: Ver.=3333, rev= 0, ck=1ABC
Serial N.= ML36AP183410001
Dial Tel.= 0201010101010

NORMAL OPERATION

U125AA OUT= 40%VA, Batt= 35% 5=0N

EXIT

Maintenance



The Frequency Converter is designed and produced to last a long time, even in the most severe service conditions. It should be remembered however that this is electronic power equipment, which requires periodic maintenance. Moreover, some components have a limited lifespan and as such must be periodically checked and replaced: in particular the batteries, the fans and in some cases the electrolytic capacitors. It is therefore recommended to implement a planned maintenance program which should be entrusted to specialized personnel authorized by the manufacturer.
Our Technical Support Team is ready to help you for any question and for planned maintenance.

Periodic maintenance (to be carried out by trained personnel and with doors closed)

The following operations (which must be done with the doors closed) should be carried out periodically (e.g. once a month, or more frequently in particularly harsh environmental conditions):

- Ensure that the air intake slots (located on the front door and at the back of the cabinet) and the output grilles located on the top of the cabinet are clean;
- Ensure that the FC is working properly (the message “NORMAL OPERATION” will appear on the display panel). If an alarm message is displayed, check the meaning in the manual before contacting the technical support service;
- Perform a battery test via the display panel.

1.1.29 Maintenance inside the FC (trained personnel only)



Maintenance inside the FC may only be carried out by trained personnel. The FC is designed to power the load when it is disconnected from the mains power supply.

High voltage is present inside the FC even when the mains power supply and the battery have been disconnected

After disconnecting the mains power supply and the battery cabinet, trained service personnel must wait at least ten minutes for the capacitors to discharge before working on the inside of the equipment.

1.1.30 Planned maintenance for batteries (trained personnel only)

The system automatically controls the efficiency of the batteries every 24 hours and sounds an alarm when the efficiency is lower than that calculated, according to the stored capacity value.

The lifespan of the batteries rely on the operating temperature and to the number of cycles (charge and discharge) the battery has experienced.

The capacity is not constant but increases after some cycles then remains constant for several hundreds of cycles before decreasing permanently.

Planned maintenance of the battery concerns the following aspects:

- keeping the operating temperature in the range of 20°C - 25°C;
- performing two or three discharge and charge cycles during the first month of use;
- carrying out this operation every six months after the first month of use.

Since the batteries are a source of energy, opening the battery circuit breaker/disconnect does not eliminate the voltage inside the battery cabinet.

If the batteries are supposed to be faulty in any way, please contact **RPS technical support**.



Do not try to access the inside of the battery cabinet. There are always present high voltages near and around the batteries.



If the batteries need to be replaced, this must be done by a **specialized technician**. The replaced parts must be sent to a specialized company for recycling according to the national and local laws. Batteries are classified by law as “hazardous waste”, it is prohibited to dispose the batteries in other ways except recycling.

General characteristics

FC models MFC sizes	80 kVA	100 kVA
MECHANICAL DATA		
Width (inches [mm])	31.50 [800]	
Depth / height (inches [mm])	33.46 [850] / 74.80 [1900]	
Ventilation	Forced	
Leakage current (max)	300mA	
Noise at 1m from front (0÷100% load) (dBA)	65	65
Applicable Standards	UL Standard 1778 2 nd Edition National Electrical Code (NFPA-70) NEMA PE-1, cULus to CSA C22.2, ASME, ASA-C-39.1-1984, FCC Part 15 Subpart J Class A, NEC, OSHA, IEEE587, ANSI C 62.41-1980, ISO9000	

FC models MFC sizes	80 kVA	100 kVA
INPUT RECTIFIER		
Rated voltage	480Vac 3-phase	
Rated voltage tolerance without contrib. of battery @100% load	-10%, +15%	
Voltage tolerance in battery mode or load depending	-40%, + 15%	
Input frequency tolerance	from 45 to 65 Hz	
Rated current (480 V) (A)	94	118
Rated power (480 V)-(kVA)	78	98
Maximum current at full load and with battery recharging (A)	109	136
Maximum power absorbed at full load and with battery recharging (kVA)	90	113
Power factor at nominal voltage (400 V) and battery charge from 25% to 100% of the load	>0.99	
Current Harmonic Distortion (THDi) (with mains distortion <1%)		
% load rated load at 100%	≤ 3	
75%	≤ 5	
25÷50%	≤ 8	
Rectifier Power Walk-in	from 0 to 30 seconds (configurable)	
Rectifier delay to Power Walk-in	from 0 to 120 seconds (configurable)	

FC models MFC sizes	80 kVA	100 kVA
INTERMEDIATE D.C. CIRCUIT		
Batteries /Cells	40 / 240	
Ripple voltage with recharged battery (%)	~ 0	
Max recharge current (A)		
Full load	20	24
Load 90%	33	42
Load 80%	47	51
Load ≤ 70%	60	76

FC models MFC sizes	80 kVA	100 kVA
INVERTER		
Rated power Pf 0.9 (kVA) inductive	80	100
Active power Pf 1 (kW)	72	90
Power derating (kVA/kW) for Pf =0.8/0.9 capacitive	0.85/0.89	
Rated voltage	400Vac 3-phase + N	
Rated frequency	50Hz	
Voltage range adjustment	+5% -10%	
Voltage variation [Static]	± 1%	
Voltage variation [Dynamic]	± 5%	
Recovery time within ± 1%	20ms Conforms to standard EN 62040-3, class 1	
Crest Factor (Ipeak/Irms)	3:1	
Voltage distortion [THD] with linear load	1% (typical), 2% (max)	
Voltage distortion [THD] with non linear load	< 3%	
frequency synchronization with the bypass mains (from inverter)	± 2% (adjustable from ± 1% to ± 6% from control panel)	
frequency synchronization without the bypass mains (free-running variation)	± 0.05%	
Slew - rate variation	1Hz/sec	
Voltage unbalance ratio with balanced and unbalanced load	≤ 1%	
Phase angle deviation with balanced and unbalanced load	120 ± 1 °el	
Overload with reference to the rated power:		
Three phase	110% for 60min, 125% for 10min, 150% for 1min	
Single phase	200% for 7 second	
Short circuit current	180% for 1 second with current limiting	
Phase / Phase		
Phase / Neutral	300% for 1 second with current limiting	
Inverter efficiency (%)	95%	
Normal mode AC/AC efficiency	93%	
Normal mode heat rejection (BTU/Hr)	18,500	23,120

Rated currents

WARNINGS



To reduce the risk of fire, connect only to a circuit provided with branch circuit protection with maximum current rating per the table, below, in accordance with the National Electrical Code, ANSI/NFPA 70.

Use at least 75°C rated copper wire. Minimum wire size is based on full load ratings applied to NEC Code Table 310-16. Code may require a larger AWG size than shown in this table because of temperature, number of conductors in the conduit, or long service runs. Follow local requirements. Branch circuit protection must be provided for the input circuits as part of the installation.

Input

FC models	Nominal Current	Maximum Current	OCP Current	OCP Device rating ¹⁻³	Bolt Size (in)	Phase and Neutral Conductor	Ground Wire
80 kVA	120.3A	136A	170A	175A	5/16	3/0	6 AWG
100 kVA	150.4A	160A	200A	200A	5/16	250 kcmil	4 AWG

Output

FC models	Nominal Current	Bolt Size (in)	Phase and Neutral Conductor	Ground Wire
80 kVA	115.5A	5/8	2/0	6 AWG
100 kVA	144.3A	5/8	4/0 or 250 kcmil	4 AWG

Battery

FC models	Nominal Current	Maximum Current	OCP Device rating	Bolt Size (in)	Phase Conductor	Ground Wire
80 kVA	188A@480V	250A@400.8V	250A	3/8	300 kcmil	6 AWG
100 kVA	236A@480V	281A@400.8V	300A	3/8	400 kcmil	4 AWG



1. Over Current Protection Device, must be rated for branch circuit protection.
2. Output circuit protection requirement is determined by distribution circuit. Smaller wire may be used for load wiring if rated load current is not needed and the appropriate circuit protection is applied. Output circuit protection must be provided as a part of the installation.
3. Input and output circuit protection must be provided by others as part of the FC installation



Per NEC article 300-20(2), all three-phase conductors must be run in the same conduit. Neutral and ground must be run in the same conduit as the phase conductors. Conduit is to be sized to accommodate one neutral conductor the same size as the phase conductor and one ground conductor. If two neutral conductors or an oversized neutral conductor are to be installed, check the size of the conduit needed to accommodate the extra wire or size and use that conduit size in place of the conduit size listed. Conduit sizes can be chosen from NEC Table C1, type RHH, RHW, RHW-2, TW, THW, THHW, THW-2

Torque specifications

Bolt size	Torque load	
5/16	10 lbf-ft	13.5 Nm
3/8	22 lbf-ft	30 Nm
1/2	37 lbf-ft	50 Nm

Appendix A Alarm messages

Below is a list of the alarm messages that are shown on the first line of the display panel, the “A=” column shows the number that is also displayed on the right in the lower row .

ALARMS		
A=	EVENT MESSAGE	DESCRIPTION
0	NORMAL OPERATION	No Alarms are present
1	NOT USED	
2	NOT USED	
3	NOT USED	
4	MAIN LINE VOLTAGE FAIL or SWIN OFF	The power supply voltage is not correct, the load is powered with the energy stored by the battery. This alarm is present if one of the following conditions occurs: - the supply voltage or frequency of the rectifier power supply line is not within an acceptable range (see characteristics) - SWIN is open, - rectifier fault
5	PREALARM, LOW BATTERY VOLTAGE	Alarm present if the residual backup time is lower than the time set for the pre-alarm (the factory-set value is 5 minutes).
6	LOW BATTERY CHARGE or CLOSE SWB	A BATTERY TEST performed by the FClogic with the mains power supply present detected a battery voltage lower than the value calculated (see BATTERY TEST menu page 33).
7	LOW INPUT VOLTAGE or OUTPUT OVERLOAD [W]	Alarm present if one of the following conditions occurs: - the power supply voltage in input is insufficient to power the load (see general characteristics); - the active power [W] of the output load is greater than the rated value.
8	OUTPUT OVERLOAD	This indicates that the required load power, which is supplied by the inverter, is greater than the allowed rated power, thus the value indicated, expressed as a percentage %VA, exceeds the value of 100%. The same alarm is also activated when the peak load current exceeds the maximum value allowed. When this alarm is present the load must be reduced, otherwise the system will automatically transfer to the bypass line within a time that is inversely proportional to the value of the overload.
9	NOT USED	
10	INTERNAL FAULT	Alarm codes used by customer service.
11	NOT USED	
12	NOT USED	
13	NOT USED	
14	NOT USED	
15	OVERTEMPERATURE or FAN FAILURE	Alarm when one of the internal temperatures on the system card, the inverter power modules, the rectifier power modules or the transformers has exceeded the maximum value allowed. This may be caused by: - operation in an environment where the temperature is too high; - a fault in the fans.
16	INSULATION LOSS	Indicates that a signal of “insulation loss” has been received from an external device
17	INPUT VOLTAGE SEQUENCE NOT OK	Indicates that the sequence of the phases at the bypass line input is not correct. It is normally sufficient to switch any two phases over to obtain normal operation.
18	OUTPUT OFF, CLOSE SWOUT OR SWMB	Alarm when there is no output voltage because SWOUT and SWMB are both open at the same time.
19	SYSTEM OFF COMMAND ACTIVE; 8=COMMAND OFF	Alarm present when the command for total shutdown from the panel or through the RS232 connection, COMMAND STORED, has been initiated. The system executes the shutdown command with a few seconds’ delay to allow for cancellation. The command remains stored even during shutdown due to a power outage. When the power supply is restored, the system does not return to normal operation if the block

		that has been intentionally set is not deactivated; to deactivate it close SWBY or, if required, press 8.
20	REMOTE SYSTEM OFF COMMAND: ACTIVE	Same as the previous alarm, with command present from the "REMOTE" connector.
21	MEMORY CHANGED: CODE=	Code 1 the memory has been changed and the operating parameters have returned to standard values. If non-standard values were previously set, these must be personalized again. Switch the display off and then on again to remove the alarm. NOTE: codes other than 1 may be displayed temporarily during variations due to personalization, but this does not affect normal operation.
22	TIMER OFF ACTIVE	Alarm when the daily timer set for the control of the automatic shutdown and restart cycles starts operating (page 39). The values of Toff and Ton are factory-set to zero (thus the timer condition is disabled).
23	SYSTEM OFF	The system is OFF therefore the output load is not feed
24	BATTERY TEST ACTIVE	The battery test is operating
25	Parallel Cable FAULT	There is a fault in the parallel signals cable.
26	Fuse FAULT	Some optional fuses are blown
27	Battery discharge Fail	The optional battery discharging test failed.
28	NOT USED	Alarm number not used.
29	High battery temperature	The battery temperature is over the limit.
30	Slave FCoff by rectifier or SWIN OFF	In a system with common battery the inverter was switched off because the input stage failed or switched off.
31	Fan FAULT	Failure in some fans (available only when installed the fan alarm option)
32	Parallel Redund. lost: High unit power	In a parallel system, the redundancy is has been lost because the output load power is high.
33	Parallel Redund. lost: Redund. unit OFF	In a parallel system, the redundancy is has been lost because the operating units are less than the set number of units.
34	Brake circuit fail	The optional brake circuit has a failure
35	Brake circuit Overload	The optional brake circuit has an overload
36	Rectifier switched OFF by Remote command	The input converter stage is switched off by a remote command.
37	WAIT starting: NOT connect the BATTERY	The input converter is starting, it needs to wait before connecting the battery
38	FCSERVICE	The unit operation time exceeded the set time to require service.
39	BATTERY SERVICE	The battery operation time exceeded the set time to require service.
40	Battery charge < set level [Ah%]	The system is waiting to start in normal operation, after a complete battery discharging, because the battery is not charged above the requirement.
41	Input switch OFF	The external optional input switch is OFF.
42	INSULATION LOSS A.C.	The external optional ac input insulation checking device, detected the ac. insulation lossing.
43	INSULATION LOSS D.C.	The external optional dc output insulation checking device, detected the ac. insulation lossing.
44	Motor Generator parallel mode (rem.com)"	Optional operation
45	NOT USED	
46	Inverters OFF	The inverters are commanded to be OFF from an external command

Appendix B - Optional remote commands

Technical support personnel may modify the COMMAND that can be executed from the standard “INV.OFF” remote input or from the optional remote input/output card.

COMMAND		
Name	Description	Typical application
Battery charge inhibition	Disables the recharging of the battery, keeping the recharge current to a minimum, independently of the load. <i>This is done with the contact kept closed; if re-opened, the command is cancelled.</i>	When there is a generator, this allows its output power to be used only to supply the load and not also to recharge the battery.
Inhibition of synchronization with backup mains	Disables the use of the bypass line and the synchronization of the inverter. In the event of an overload or fault, the FC blocks and the load remains unpowered. <i>This is done with the contact kept closed; if re-opened, the command is cancelled.</i>	To be used when the frequency of the generator or of the backup mains is highly unstable and it is thus preferred to inhibit the synchronization of the inverter.
Battery disconnect contact	Activates the battery discharging or disconnected alarm. To be used to indicate the opening of a battery switch located external to the FC. <i>A closed contact must be provided when the external switch is opened.</i>	Displays the status of the battery disconnect.
Standby ON	Forces the selection of the FC Standby-ON operation. <i>This is done with the contact kept closed; if re-opened, the command is cancelled.</i>	To be used when the load may support mains interference or frequency variations and it is thus preferred to improve system efficiency. The load is powered if there is a mains power failure.
Battery test	Starts the automatic battery test when the FC is in normal operation. Any automatic battery test underway is terminated immediately. <i>This is achieved by switching the contact from open to closed.</i>	Checks state of the battery.
Battery test (with rectifier on)	Starts the manual battery test that continues until a block command is received or until the full discharge of the battery. Terminates any manual battery test underway. <i>This is achieved by switching the contact from open to closed.</i>	Checks state of the battery. NOTE: During this test the rectifier remains on with output voltage low in order to allow the supply of current by the battery and to prevent inverter shutdown after battery discharge.
Manual battery charging	Starts the “single first time recharge”. Terminates the first time charging underway. <i>This is achieved by switching the contact from open to closed.</i>	Activates manual remote battery charging
Activation of block on Bypass	Bypass command by means of blocking the inverter as a result of switching onto the bypass line. NOTE: The command is only executed if the bypass line is present with correct values. <i>This is achieved by switching the contact from open to closed.</i>	Load unpowered in the event of a mains outage. To be used for non-critical loads, the battery does not discharge during a mains power failure
Inhibition of block on bypass	Resets the bypass command. <i>This is achieved by switching the contact from open to closed.</i>	Cancels the previous action and disables the inverter block.
Inverter ON/OFF	UNCONDITIONAL inverter block command (the command is executed even if there is no bypass line). The FC only switches onto bypass if the bypass line is present (otherwise the load remains unpowered). <i>This is done with the contact kept closed; if re-opened, the command is cancelled.</i>	Load unpowered in the event of a mains outage. To be used for non-critical loads, the battery does not discharge during a mains power failure.
Rectifier OFF	UNCONDITIONAL rectifier blocks command. <i>This is done with the contact kept closed; if re-opened, the command is cancelled.</i>	Shuts down the rectifier and discharges the battery.